

KAMADOJOE®

A GUIDE TO KAMADO COOKING | UN GUIDE POUR LA CUISSON DE STYLE KAMADO |
UNA GUÍA PARA LA COCCIÓN CON KAMADO | EEN GIDS BIJ KAMADO-KOKEN |
EIN LEITFADEN ZUM KAMADO-KOCHEN | KAMADO SÜTÉSI ÚTMUTATÓ |
UNA GUIDA ALLA COTTURA KAMADO | EN VEILEDNING TIL
KAMADO-TILBEREDNING | ПОСОБИЕ ПО ПРИГОТОВЛЕНИЮ ПИЩИ НА
КАМАДО-ГРИЛЕ | EN GUIDE FÖR KAMADO MATBEREDARE | OPAS KAMADO
GRILLAUKSEEN | PRZEWODNIK PO GOTOWANIU KAMADO



KONNECTED JOE™ OWNER'S MANUAL | MODE D'EMPLOI DE KONNECTED JOE™ |
MANUAL DEL USUARIO DE KONNECTED JOE™ | KONNECTED JOE™: HANDLEIDING |
KONNECTED JOE™ – BENUTZERHANDBUCH | KONNECTED JOE™ HASZNÁLATI ÚTMUTATÓ |
KONNECTED JOE™ MANUALE UTENTE | KONNECTED JOE™-BRUKSANVISNING |
РУКОВОДСТВО ПОЛЬЗОВАТЕЛЯ KONNECTED JOE™ |
KONNECTED JOE™ ÄGARENS MANUAL | KONNECTED JOE™ OMISTAJAN OPAS |
GRILL KONNECTED JOE™ PODRĘCZNIK UŻYTKOWNIKA

KJ15041523

9804230002 | 231004-GH

Welcome | Bienvenue | Bienvenido | Welkom!| Willkommen | Üdvözöljük! | Benvenuti | Velkommen | Добрый день | Välkommen | Tervetuloa | Witajcie

Assembly Images are shown first. Please read and follow all warnings and instructions before assembling and using the appliance.

Les images de montage sont montrées en premier. Veuillez lire et suivre tous les avertissements et toutes les instructions avant de monter et d'utiliser l'appareil.

Las imágenes de ensamblaje se muestran primero. Lea y siga todas las advertencias e instrucciones antes de ensamblar y usar el artefacto.

De eerste pagina's zijn afbeeldingen van de montage. Lees en volg alle waarschuwingen en instructies, voordat u het apparaat monteert en gebruikt.

Die Montagebilder werden zuerst angezeigt. Bitte lesen und befolgen Sie alle Warnungen und Anweisungen, bevor Sie das Gerät montieren und verwenden.

Az összeszerelési képek jelennek meg először. A készülék összeszerelése és használata előtt olvassa el, majd tartsa be az összes figyelmeztetést és utasítást.

Immagini del montaggio all'inizio. Leggere e rispettare tutte le avvertenze e le istruzioni prima di montare e mettere in funzione l'apparecchio.

Monteringsillustrasjoner er vist først. Les og følg alle advarsler og instruksjoner før montering og bruk av apparatet.

Вначале идут сборочные схемы. Прежде чем приступить к сборке и эксплуатации устройства, прочтите все предупреждения и инструкции и следуйте им.

Monteringsbilder visas först. Läs och följ alla varningar och anvisningar innan du monterar och använder apparaten.

Laitteen kokoonpanokuvat näytetään ensin. Lue ja noudata kaikkia varoituksia ja ohjeita ennen laitteen kokoamista ja käyttöä.

Ilustracje dotyczące montażu są zamieszczone na początku. Przed przystąpieniem do montażu i użytkowaniem urządzenia proszę przeczytać wszystkie ostrzeżenia i instrukcje i ich przestrzegać.

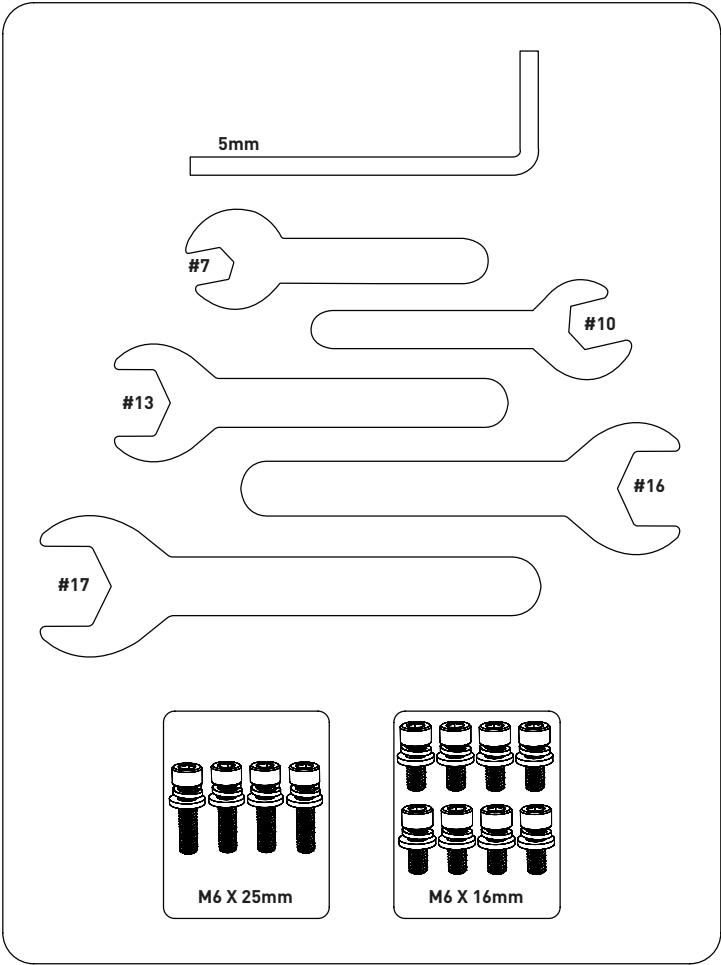

1

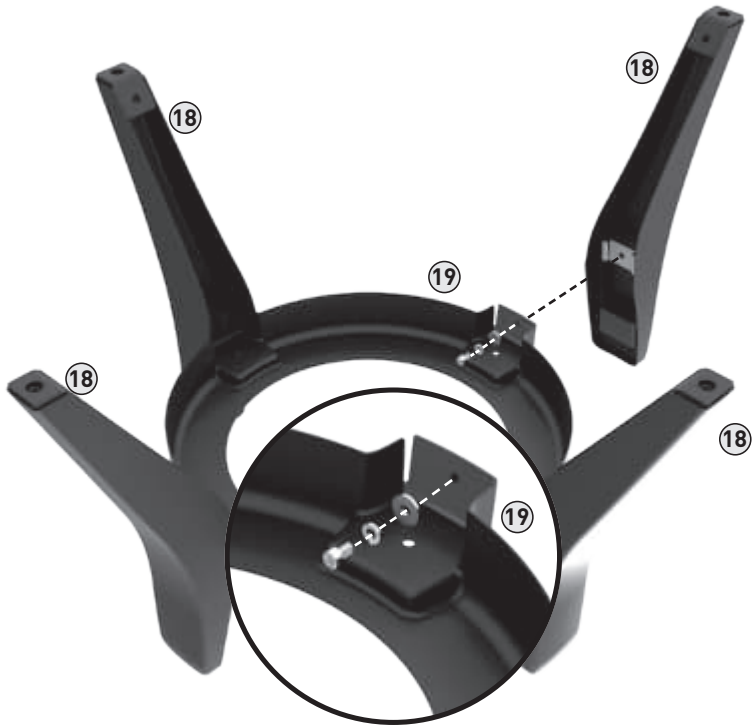

2



3

#16

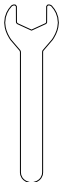

4

M6X25

X4



M6

X4



M6

X4



5

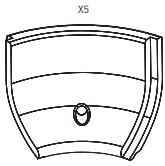

6



7



8

#10

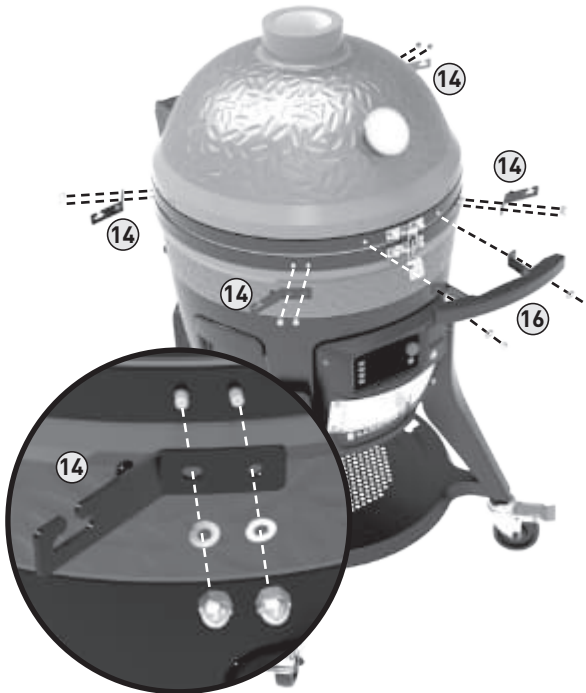

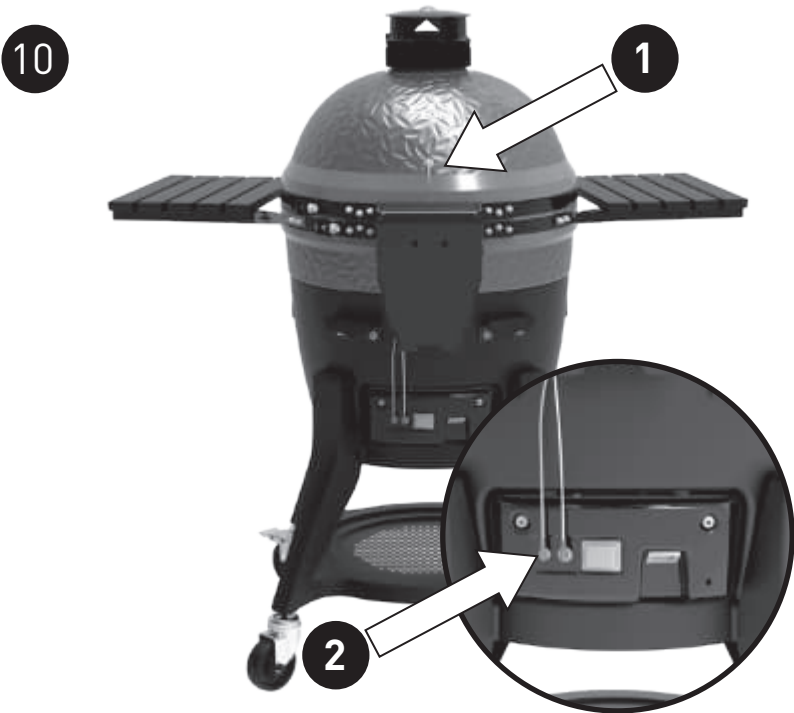



WARNING

Failure to follow these instructions could result in fire, explosion or burn hazard which could cause property damage, personal injury or death.



CARBON MONOXIDE HAZARD

- Carbon wood chips, wood chunks, wood pellets, charcoal and propane gives off carbon monoxide, which has no odor and can cause death.
- DO NOT burn wood chips, wood chunks, wood pellets, charcoal or propane inside homes, vehicles, tents, garages, or any enclosed areas.
- **USE ONLY OUTDOORS** where it is well ventilated.

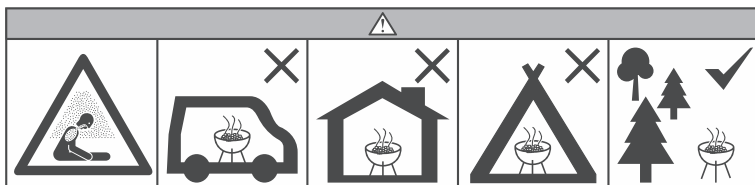

WARNINGS AND IMPORTANT SAFEGUARDS READ ALL INSTRUCTIONS

WARNING! This grill will become very hot. Do not move it during operation.

WARNING! Accessible parts may become hot during use. Young children should be kept away.

WARNING! Do not use indoors!

WARNING! Never use gasoline-type lantern fuel, kerosene, charcoal lighter fluid, or similar liquids to start or freshen up a fire in this grill. Keep all such liquids well away from the grill when in use.

WARNING! Keep children and pets away from grill at all times. Do NOT allow children to use grill. Close supervision is necessary when children or pets are in the area where grill is being used.

WARNING! Do not use Match Light charcoal!

WARNING! Risk of Fire! Do not over-fire. When flame spills out of the grill, you are over-firing. Over-firing may ignite creosote or will damage the grill.

WARNING! Do not use spirit or petrol for lighting or re-lighting! Use only firelighters complying to EN 1860-3!

FOLLOW THESE GUIDELINES TO PREVENT THIS COLORLESS, ODORLESS GAS FROM POISONING YOU, YOUR FAMILY OR OTHERS.

- Know the symptoms of carbon monoxide poisoning: headache, dizziness, weakness, nausea, vomiting, sleepiness, and confusion. Carbon monoxide reduces the blood's ability to carry oxygen. Low blood oxygen levels can result in loss of consciousness and death.
- See a doctor if you or others develop cold or flu-like symptoms while cooking or in the vicinity of this appliance. Carbon monoxide poisoning, which can easily be mistaken for a cold or flu, is often detected too late.
- Alcohol consumption and drug use increase the effects of carbon monoxide poisoning.

Carbon monoxide is especially toxic to mother and child during pregnancy, infants, the elderly, smokers, and people with blood or circulatory system problems, such as anemia, or heart disease.

Charcoal NOT included



WARNINGS AND IMPORTANT SAFEGUARDS

- Do not use the grill in a confined and/or habitable space e.g. houses, tents, caravans, motor homes, boats. Danger of carbon monoxide poisoning fatality.
- Never operate grill under overhead construction such as roof coverings, carports, awnings or overhangs.
- Always use grill in accordance with all applicable local, state and federal fire codes.
- Before each use check all nuts, screws and bolts to make sure they are tight and secure.
- Grill is for OUTDOOR USE ONLY.
- Keep a minimum 10 ft. (3m) clearance of all combustible materials such as wood, dry plants, grass, brush, paper or canvas.
- Do not place any type of insulation in the required clearance space surrounding the grill.

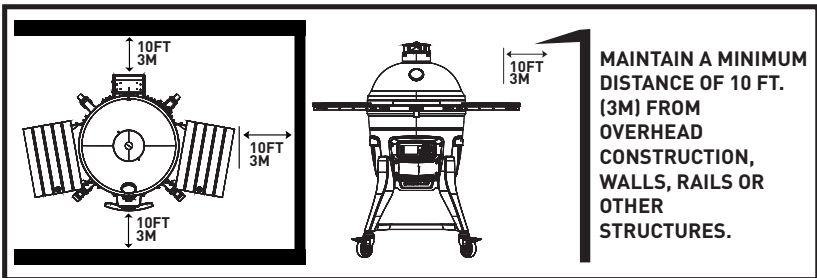

- Never use grill for anything other than its intended use. This grill is NOT for commercial use.
- Accessory attachments not supplied by Kamado Joe are NOT recommended and may cause injury.
- Use of alcohol, prescription or non-prescription drugs may impair user's ability to assemble or safely operate grill.
- Keep a fire extinguisher accessible at all times while operating grill.
- When cooking with oil or grease, have a type BC or ABC fire extinguisher readily available.
- In the event of an oil or grease fire do not attempt to extinguish with water. Immediately call the fire department. A type BC or ABC fire extinguisher may, in some circumstances, contain the fire.
- Use grill on a level, non-combustible, stable surface such as dirt, concrete, brick or rock. An asphalt surface (blacktop) may not be acceptable for this purpose.
- Grill MUST be on the ground. Do not place grill on tables or counters. Do NOT move grill across uneven surfaces.
- Do not use grill on wooden or flammable surfaces.
- Keep grill clear and free from combustible materials such as gasoline and other flammable vapors and liquids.
- Do not use the barbecue near combustible materials.
- Do not leave grill unattended.
- This appliance generates heat during use. Do not touch hot surfaces. Use handles or knobs. Always protect your hands with non-slip oven mitts or similar.



WARNINGS AND IMPORTANT SAFEGUARDS

- Do NOT allow anyone to conduct activities around grill during or following its use until it has cooled.
- Do not use accessories not specified for use with this appliance.
- Do not use products not specified for use with this oven.
- Never use glass, plastic or ceramic cookware in grill. Never place empty cookware in grill while in use.
- Never move grill while in use. Allow grill to cool completely (below 115°F (45°C)) before moving or storing.
- Do not store grill with hot ashes or charcoal inside grill. Store only when fire is completely out and all surfaces are cold.
- Never use grill as a heater. READ CARBON MONOXIDE HAZARD.
- The grill is HOT while in use and will remain HOT for a period of time afterwards and during cooling process. Use CAUTION. Wear protective gloves/mitts.
- DO NOT bump or impact the grill to prevent personal harm, damage to grill or spillage/splashing of hot cooking liquid.
- Be careful when removing food from grill. All surfaces are HOT and may cause burns. Use protective gloves/mitts or long, sturdy cooking tools for protection from hot surfaces or splatter from cooking liquids.
- Do not touch HOT surfaces.
- Grill is HOT during use. To avoid burns, keep face and body away from vents and when opening lid. Steam and hot air are expelled during use.
- When cooking above 350°F (175°C), carefully open the grill (or burp the grill) each time you lift the grill dome to prevent flashback – a surge of white-hot heat caused by a rush of oxygen. Partially opening the lid 2-3 inches (5-8cm) and allowing heat to escape for about 5 seconds should prevent this.
- Air dampers are HOT while the grill is in use and during cooling. Wear protective gloves when adjusting.
- ATTENTION! When running the grill in automatic mode, the bottom vent should be closed completely at all times.
- Grill has an open flame. Keep hands, hair and face away from flame. Do NOT lean over grill when lighting. Loose hair and clothing may catch fire.
- DO NOT obstruct flow of combustion and ventilation.
- Do not cover cooking racks with metal foil. This will trap heat and may cause damage to the grill.
- Never leave HOT coals or ashes unattended.
- Fuel should be kept red hot for at least 30 minutes prior to use.
- Do not cook before the fuel has a coating of ash.
- Do not remove ash drawer while ashes and charcoal are HOT.
- Use protective gloves when handling this grill or working with fire. Use protective gloves or long, sturdy tools when adding wood or charcoal.
- Never use charcoal lighting fluid, gasoline, alcohol or other highly volatile fluids to ignite charcoal. These fluids can explode and cause injury or death.
- The maximum amount of charcoal for the Konnected Joe™ is 6 lbs. (2.7 kg). Never overfill charcoal grate. This can cause serious injury as well as damage to the grill.
- DO NOT use Match Light charcoal.
- Dispose of cold ashes by placing them in aluminum foil, soaking with water and discarding in a non-combustible container.
- Wear protective gloves when lifting and use extreme caution.



WARNINGS AND IMPORTANT SAFEGUARDS

- When using electrical appliances, basic safety precautions should always be followed including the following: 1) Do not plug in the appliance until fully assembled and ready for use. 2) Use only approved grounded electrical outlet. 3) Do not use during an electrical storm. 4) Do not expose appliance to rain or water at any time.
- To protect against electrical shock do not immerse cord, plug or control panel in water or other liquid.
- Do not operate any appliance with a damaged cord or plug, or after appliance malfunctions or has been damaged in any manner.
- If the supply cord is damaged, it must be replaced by a special cord or assembly available from the manufacturer or its service agent.
- Extension cords may be used if care is exercised in their use.
- If an extension cord is used: 1) The marked electrical rating of the extension cord should be at least as great as the electrical rating of the appliance; and 2) The cord should be arranged so that it will not drape over a counter top or tabletop where it can be pulled by children or tripped over unintentionally.
- The extension cord must be a grounding-type 3-wire cord.
- Outdoor extension cords must be used with outdoor use products and are marked with suffix “W” and with the statement “Suitable for Use with Outdoor Appliances.”
- CAUTION - To reduce the risk of electric shock, keep extension cord connection dry and off the ground.
- Do not let cord hang on or touch hot surfaces.
- Do not place cord on or near a hot gas or electric burner, or in a heated oven.
- To disconnect, turn controller “OFF”, turn grill “OFF”, then remove plug from outlet.
- Unplug from outlet when not in use and before cleaning.
- Do not clean this product with a water sprayer or the like.
- Always operate grill on a level surface.
- This appliance is not intended for use by persons (including children) with reduced physical, sensory or mental capabilities, or lack of experience and knowledge, unless they have been given supervision or instruction concerning use of the appliance by a person responsible for their safety.
- Keep children and pets away from grill at all times. Do NOT allow children to use grill. Close supervision is necessary when children or pets are in the area where grill is being used.
- Cleaning and user maintenance shall not be made by children without supervision.
- This appliance incorporates an earth connection for functional purposes only.
- The appliance should be supplied through a residual current device (RCD) having a rated residual operating current not exceeding 30 mA.
- The appliance is to be connected to a socket-outlet having an earthing contact.
- The supply cord should be regularly examined for signs of damage and the appliance is not to be used if the cord is damaged.



ELECTRIC REQUIREMENTS

220-240VAC, 50/60HZ, 475-590W, 3-Prong Grounded Plug.

PARTS LIST

1. TOP VENT (1)
2. TEMPERATURE PROBE (1)
3. GRILL DOME (1)
4. HALF MOON COOKING GRATES (2)
5. ACCESSORY RACK (1)
6. CERAMIC HEAT DEFLECTORS (2)
7. DIVIDE & CONQUER® FLEXIBLE COOKING RACK (1)
8. STAINLESS STEEL FIREBOX RING (1)
9. LEFT SIDE SHELF (1)
10. RIGHT SIDE SHELF (1)
11. AMP (ADVANCED MULTI-PANEL) CERAMIC FIREBOX (5)
12. ASH TOOL (1)
13. GRILL GRIPPER (1)
14. SIDE SHELF BRACKETS (4)
15. SLIDE-OUT ASH DRAWER (1)
16. FRONT HANDLE (1)
17. KONECTED JOE BODY (1)
18. LEGS (4)
19. TOP PLATE (1)
20. BOTTOM PLATE (1)
21. NON-LOCKING SWIVEL CASTERS (2)
22. LOCKING SWIVEL CASTERS (2)
23. POWER CORD (3)
24. HINGE DISENGAGEMENT TOOL KIT (1)
25. MEAT PROBE (1)



GRILL SET-UP

UNBOXING YOUR GRILL

- 1 Cut the plastic bands and remove the top and side panels of the shipping container.
- 2 Set the grill cart box aside.
- 3 Open the dome of the grill and remove the components from the inside of the grill. Handle the internal ceramic parts with care.

KAMADO JOE GRILL WITH CART

- 1 Assemble the grill cart.
- 2 Once the internal components of the grill have been removed, lift the grill out of the container and into the cart. Due to the weight of this grill, we highly recommend two people perform this task. Lift the grill by the rear and side handles only. Do NOT lift the grill by the side shelf tabs, hinge, or front handle. Wear protective gloves when lifting and use extreme caution.
- 3 Adjust the grill in the cart so the lower grill vent is facing the front of the cart. The front side of the cart is the side with the two locking casters.

KONNECTED JOE™ BUILT IN GUIDE

IMPORTANT INSTALL NOTES:

Please use this as a general guide for installing your Konnected Joe into a built-in outdoor kitchen or grill table. We highly recommend that the actual grill being installed be measured. Drawing is not to scale.

Table should be fixed on the ground or wall. Non-flammable building materials are required for construction.

TABLE REQUIREMENTS:

MATERIALS: Ensure the materials used are non-combustible and can handle high temperatures.

BASE: Ensure there is a hole 12.25in (32cm) in diameter directly underneath the grill to allow cool air to reach the bottom of the grill. Use caution, sparks and hot ash can reach the bottom of the grill.

Note: the Kamado Joe ceramic feet are not to be used in absence of the hole under the grill. The hole is required and the ceramic feet are NOT compatible with Konnected Joe.

ACCESS: Ensure there is rear access to the main power switch. Ensure there is front access so that the Kontrol Board or Ash Drawer are not blocked.

CLEARANCE: Ensure there is space between the top of the table and the edge of the grill. The table top SHOULD NOT make direct contact with the grill.

SIDE VIEW

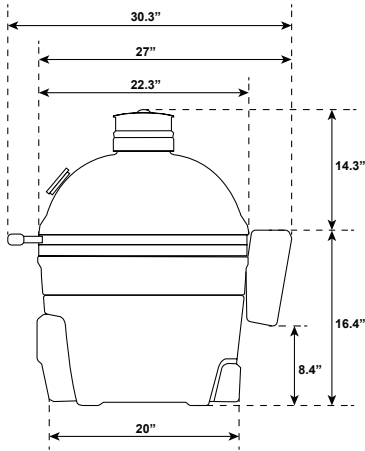

OPEN CLEARANCE

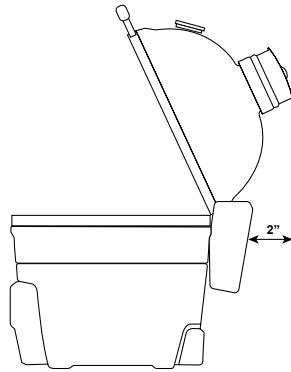
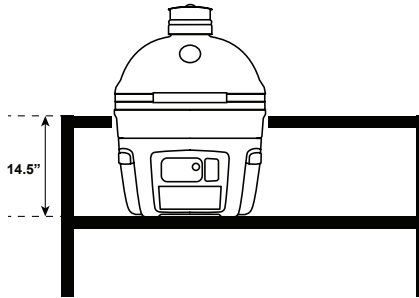

TABLE FRONT



TOP VIEW

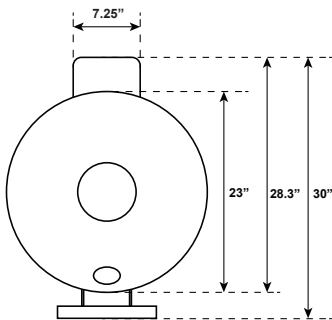
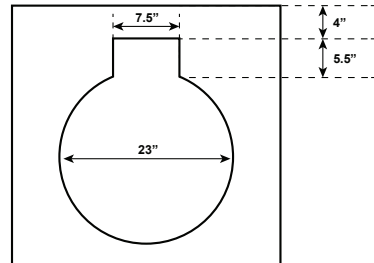

TABLE TOP





QUICK START GUIDE

WARNING - Do not use an external fan and/or controller at any time.

STARTING IT UP

Your Konnected Joe can be operated using “classic cook mode” or “automatic cook mode”. The classic mode will provide you a traditional kamado cooking experience. In the automatic mode, your grill will utilize the Kontrol Board™ and the Kontrol Fan™ to maintain the temperature for you automatically.

CLASSIC MODE:

1. Add charcoal to firebox and light using one or two firestarters. You can also light the charcoal without firestarters by pressing the AFS (automatic fire starter) button to engage the element to ignite the charcoal. The element is ON when the red light is glowing. The element will stay on for 10 minutes. The ignitor will automatically turn off if the grill temperature is above 190F (88C). You can also press and hold the AFS button to turn the element OFF if desired.
2. Leave dome open for 10 minutes with the bottom vent fully open.
3. Close the dome.
4. Begin closing the top vent and bottom vent when the dome temperature is within 50°F (10°C) of your target.

AUTOMATIC MODE:

NOTE - the first time the lid is opened after the controller is powered on, the accessory screen will appear. Please refer to the accessory screen section of the instruction manual.

1. Clean out any remaining ash in the firebox from a previous cook. Old ash can prevent the charcoal from proper ignition. It is recommended to use your ash tool to scrape and clean out the firebox and ash drawer. Do this while the unit is cold.
2. Add charcoal to the firebox.
3. Close the bottom vent fully. **ATTENTION!** When running the grill in automatic mode, the bottom vent should be closed completely at all times.
4. Close the dome.
5. Power on your grill with the switch on the rear. Power on your controller.
6. Set your temperature on your controller and position the vents as described.
7. Press the AFS (automatic fire starter) button to engage the element to ignite the charcoal. The element is ON when the red light is glowing. The element will stay on for 10 minutes. The ignitor will automatically turn off if the grill temperature is above 190F (88C). You can also press and hold the AFS button to turn the element OFF if desired.



AFS BUTTON

MAINTAINING TEMPERATURE

CLASSIC MODE:

To lower the temperature, decrease the airflow through the grill by closing the vents. Conversely, raise the temperature by opening the vents. Adjustments to the vents are not immediate—allow 10–15 minutes for a vent change to take effect. Because your ceramic Kamado Joe retains heat so well, it can take some time to fully heat. Give your grill 20–40 minutes to stabilize the temp before you start cooking.

AUTOMATIC MODE:

ATTENTION! When running the grill in automatic mode, the bottom vent should be closed completely at all times. Your Konnected Joe will automatically maintain the set temperature when running in automatic mode. Please ensure your top vent is set as described on the Kontrol Board. Because your ceramic Kamado Joe retains heat so well, it can take some time to fully heat. Give your grill 20–40 minutes to stabilize the temp before you start cooking.

Heat deflectors are NOT to be installed when maintaining temperatures above 400°F (205°C). For maintaining temperatures below 400°F (205°C), it is best to cook with the heat deflectors installed.

For optimum temperature maintenance in automatic mode, keep the lid closed as much as possible.

COOLING IT DOWN

CLASSIC MODE:

1. When finished cooking, close the bottom vent completely.
2. Once the temperature falls below 400°F (205°C), close the top vent.
3. Do not cover the grill until the dome is cool to the touch.

AUTOMATIC MODE:

1. When finished cooking, power off your controller and power off your grill.
2. Keep the bottom vent closed completely.
3. Once the temperature falls below 400°F (205°C), close the top vent.
4. Do not cover the grill until the dome is cool to the touch.

KONTROL BOARD™

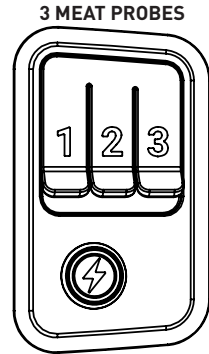
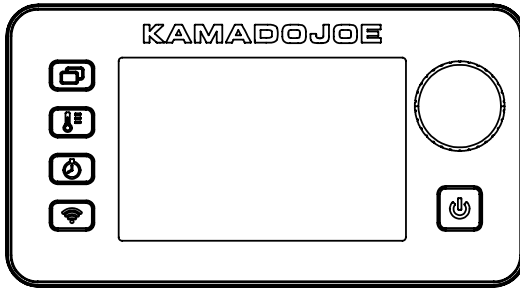

Power – Press button to power controller on. Press and hold to power controller off.



AFS (automatic fire starter) – Press button to engage the element to ignite the charcoal. The element is ON when the red light is glowing. The element will stay on for 10 minutes. The ignitor will automatically turn off if the grill temperature is above 190F (88C). You can also press and hold the AFS button to turn the element OFF if desired.



Screen Cycle – Press button to cycle through different controller views.



Set Temperature – Press button. Turn knob to desired temperature. Press button again to set the temperature.



Set Time:

Countdown Timer

1. Press button.
2. Turn knob to desired hours.
3. Press button to set hours.
4. Turn knob to desired minutes.
5. Press button to set minutes.
The timer will start.
6. Press button to pause and resume timer.
7. Press and hold button to reset timer.

Count Up Timer

1. Press and hold button.
2. Timer will begin counting up from 00:00. Timer will count by Minutes:Seconds and then Hours:Minutes.
3. Press button to pause and resume timer.
4. Press and hold button to reset timer.

Screen Saver Mode:

Press and hold the screen cycle button to activate screen saver mode. In screen saver mode all set temperatures and timers remain active. The screen will turn black and the Kamado Joe logo will pulse dimly on the screen. To exit screen saver mode, press any button. Screen saver mode will also be deactivated if: a meat probe has reached the set temperature, a previously set timer has been reached, open lid status is activated, or an error message is triggered.

Accessory Mode:

The first time the lid is opened after the controller is powered on, the accessory screen will appear. If you wish to use one of the listed accessories, press the button on the controller that corresponds to the accessory, if you do not wish to use an accessory, close the lid. Your selected accessory should appear in the top right hand corner of your screen on all modes except the graph mode. Resume normal use of your controller to set your temperatures, timers and meat probes.

Full Griddle:

Please note, the full griddle accessory mode is for use with a griddle that fills the entire cooking surface. Operate the grill under normal conditions for a half moon griddle surface. When using a griddle, it is best to shut the lid so the grill can regulate the temperature.

How do I switch from Fahrenheit to Celsius or Celsius to Fahrenheit on the grill controller?

STEP 1 = power grill OFF with switch on rear

STEP 2 = power ON grill with switch on rear (grill will beep, controller will turn on, then turn black)

STEP 3 = while controller is black, press and HOLD set temp button

STEP 4 = press POWER button on controller

STEP 5 = scroll knob to switch between F and C or C and F

NOTE = you can also switch from C to F or F to C in the App



Pairing Grill with Smart Device(s) (BLUETOOTH+WIFI):

1. Download the Kamado Joe app from the Apple App Store or Google Play Store onto your smart device(s).

NOTE - During normal operation, the app may experience a slight delay from your grill controller readings.

2. Once the download is complete, open the Kamado Joe app and follow the instructions for pairing your Bluetooth + WIFI grill and smart device(s).

NOTE: Please ensure your WiFi Network is capable of 2.4Ghz. If you have dual band router(2.4Ghz and 5Ghz), choose the 2.4Ghz network. Both networks should have different names to ensure proper pairing.

This device complies with Part 15 of the FCC Rules. Operation is subject to the following two conditions:

1. This device may not cause harmful interference.
2. This device must accept any interference received, including interference that may cause undesired operation. try to correct the interference by one or more of the following measures:

FCC Warning

Warning: Changes or modifications to this grill not expressly approved by the party responsible for compliance could void the user's authority to operate the equipment.

FCC Statement

This equipment has been tested and found to comply with the limits for a Class B digital device, pursuant to Part 15 of the FCC Rules. These limits are designed to provide reasonable protection against harmful interference in a residential installation. This equipment generates, uses and can radiate radio frequency energy and if not installed and used in accordance with the instructions, may cause harmful interference to radio communications.

However, there is no guarantee that interference will not occur in a particular installation. If this equipment does cause harmful interference to radio or television reception, which can be determined by turning the equipment off and on, the user is encouraged to try to correct the interference by one or more of the following measures:

1. Reorient or relocate the receiving antenna.
2. Increase the separation between the equipment and receiver.
3. Connect the equipment into an outlet on a circuit different from that to which the receiver is connected.
4. Consult the dealer or an experienced radio/TV technician for help.

Note: If you lose connection, grill will continue as programmed. Grill can be operated from the control panel if pairing or connection fails.

Wireless Transmitter

Transmitter and WiFi Characteristics = RF 0dBm / 2412-2484 MHz

AIR LIFT HINGE ADJUSTMENTS

The Air Lift Hinge on your Connected Joe is already pre-adjusted for ideal balance and stability. Follow these instructions for any additional adjustment to suit your personal preferences.

Caution: Air Lift Hinge under high tension.

KONNECTED JOE HINGE

- 1 Open the dome of your Connected Joe grill.
- 2 Place the 17mm wrench on the nut on top of the spring retainer (see Inset 1).
- 3 To make the dome easier to raise, rotate the 17mm wrench clockwise as shown. Remove the wrench and check the dome action for every full rotation of the nut. If you want the dome to feel heavier, rotate the nut counter-clockwise. Remove the wrench and check the dome action for every full rotation of the nut. Do not adjust the nut so that it contacts the nut under the connector (see Inset 1).

HINGE SAFETY INFORMATION

Do not attempt to disassemble the hinge from your grill without the proper hardware. Only minor adjustments to the weight of the dome should be made.

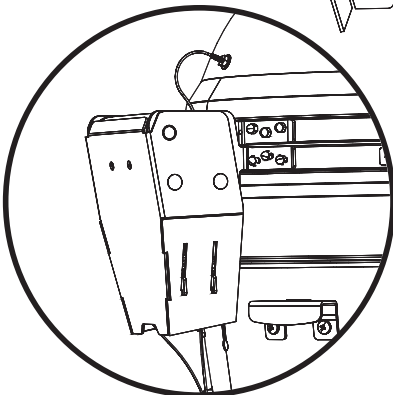
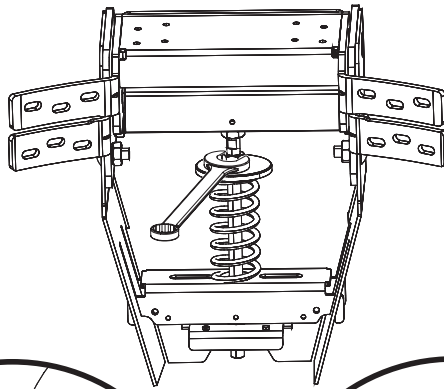

Air Lift Hinge

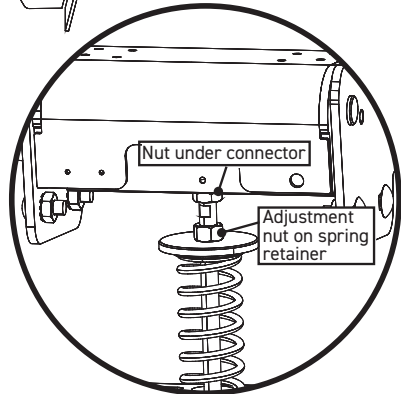

Inset 1

SAFETY INFORMATION DISENGAGEMENT TOOL

HINGE

Do not attempt to disassemble the hinge or loosen the bands from your grill without the disengagement tool kit.

DISENGAGEMENT TOOL

To install the disengagement tool kit, first place the spacer, then washer, then hex nut on the spring retainer on the bottom side of the hinge. Installing the disengagement tool will release the tension on the spring allowing you to remove the hinge or bands safely from the grill

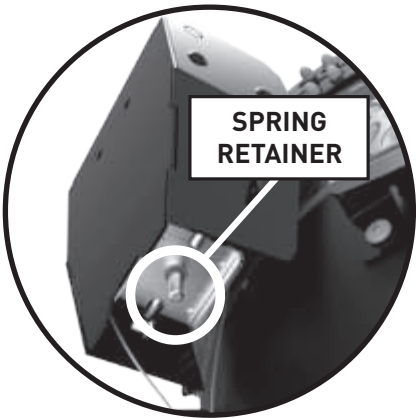

LATCH ADJUSTMENTS

The latch on your Connected Joe is already preset for an ultra-tight seal. Use these instructions if any adjustments should be needed.

KONNECTED JOE LATCH

To tighten and loosen the latch setting, use a small Allen wrench. Adjust the set screw to lower the latch plate and add a spacer. Once a spacer is added, reinstall the latch plate by tightening the set screw.

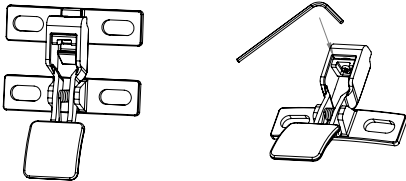

Gripper

Use your grill gripper to handle your cooking grates.

CAUTION - Cooking grates are hot!

Use the grill gripper to re-position the cooking grates throughout your cook.

Note - The grates should be as close together as possible.



Cleaning & Care

Your Kamado Joe grill is made of quality materials, so general care and maintenance is minimal. The best way to protect your Kamado Joe from the elements is with a grill cover. Light cracked porcelain called crazing is part of the natural characteristic.

SELF-CLEANING

- 1 Add charcoal and light it.
- 2 Install the Divide & Conquer® flexible cooking rack in the top position and both heat deflectors on the accessory rack.
- 3 Using classic cook mode, open the top and bottom air vents fully and let the temperature inside the grill rise to 600°F (315°C) with the dome closed.
- 4 Hold the temperature at around 600°F (315°C) for 15-20 minutes.
- 5 Close the bottom vent fully and wait another 15-20 minutes to close the top vent.

This process will burn off residue from the inside of your grill. Before cooking again, brush the cooking grates with a standard grill brush. Brush the ceramics and heat deflectors with a soft bristle brush. Scoop or vacuum out all cold ash from the bottom of the grill. During regular use when your heat deflectors get dirty, flip them over for the next cook and the heat will remove the unwanted residue.

Once or twice a year, you should do a more thorough cleaning of the inside of the grill. Remove the firebox panels from the inside of the grill. Remove all ash or debris. Use a soft bristle brush to clean the inside ceramic surface and vacuum all cold debris from the bottom of the grill before replacing the internal components.

GASKET

Self-cleaning through natural heat cycle recommended. Do not use chemical based cleaners on the gasket. If absolutely necessary, gently wipe off any spills or moisture. Do not scrub or abrade the gasket if cleaning. Excessive rubbing can cause wear.

SAVE THESE INSTRUCTIONS

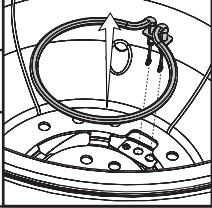

Troubleshooting

SYMPTOM	CAUSE	POSSIBLE SOLUTION	
Controller not ON	Grill not powered ON	Check switch on rear of grill.	
	Controller not powered ON	Press power button on Kontrol Board.	
	Not plugged in	Plug cord into rear of grill and into wall outlet.	
	Circuit breaker tripped	Check wall outlet circuit breaker and reset if tripped.	
	Electrostatic charge	When the product is disturbed by electrostatic discharge, the controller may restart, then enter standby mode and needs to be restarted by the user to restore normal operation, this phenomenon is normal.	
Fan not ON	Pit probe has reached the set temperature	Once the set temperature is reached, the fan will turn off. Once the cabinet temperature falls below the set temperature, the fan will restart. The fan will continue adjusting itself automatically to maintain the set temperature.	
	Dome lid open	For safety, the fan should not stoke the fire when the lid is open. Once the lid is shut, the fan will continue under normal operation.	
	Lid switch not engaged	Your lid switch may not be making contact when your dome is closed. If the dome is closed and the fan is not ON when it should be, you may need a new lid switch.	
	ERROR – Max Temp Fault P	See below.	
Slow heating	Ash buildup from previous use	Before starting your unit, remove any leftover ash from the firebox and ash drawer that may be left from a previous cook. Ash buildup can prevent proper charcoal ignition.	
	Low charcoal	Refill firebox with charcoal.	
	Lid open	Close lid.	
	Fan not on	See fan not on section.	
Element not ON	AFS button not pressed	Ensure AFS button was pressed and button is glowing red.	
	Element damaged	Turn off main power from grill. Remove element from grill, inspect for any visual damage.	
	Element not seated properly	Turn off main power from grill. Remove element completely from grill, reconnect element to grill and be sure to fully press element into connectors.	
ERROR: Probe Fault – P	Pit probe faulty	Check to ensure pit probe is plugged into rear of the grill.	
		Check to ensure pit probe connection is fully seated.	
		Check to ensure no debris is in the pit probe jack.	
		Unplug the unit from the wall, wait 10seconds and reconnect.	
ERROR: Probe Fault - M	Meat probe faulty	Contact Kamado Joe Customer Support.	
ERROR: Startup Time-Out	Charcoal failed to ignite. Unit did not reach 150F (65C) in under 10mins	Ensure old ash from previous use is not left in the firebox.	
		Ensure the AFS button was pressed and element is working.	
		Ensure proper vent placement for classic or automatic mode.	
		Ensure charcoal is not empty.	
		Restart	
ERROR: Max Temp Fault – P	Grill overheated	Turn off grill.	
		Check for cause of overheat. - Grease fire - Fan malfunction	
		Eliminate cause of overheat.	
		Restart grill.	
ERROR: Max Temp Fault - M	Meat probe temperature above 300F (149C)	Using protective gloves, remove meat probe from unit.	
		Unplug from controller.	
		Allow meat probe to cool.	

LIMITED WARRANTY

This warranty applies to all Kamado Joe® products.

Limited Lifetime Warranty on Ceramic Parts

Kamado Joe® warrants that key ceramic parts used in this Kamado Joe® grill and smoker are free of defects in material and workmanship for as long as the original purchaser owns the grill.

5-Year Warranty on Metal Parts and Kettle Joe Grills

Kamado Joe® warrants that key metal and cast iron parts used in this Kamado Joe® grill and smoker are free of defects in material and workmanship for a period of five (5) years.

3-Year Warranty on Electronic Components, Heat Deflectors, and Pizza Stones

Kamado Joe® warrants that electronic components of this Kamado Joe® grill and smoker are free of defects in material and workmanship for a period of three (3) years.

2-Year Warranty on Miscellaneous Components and Standalone Accessories

Kamado Joe® warrants that any miscellaneous components used in this Kamado Joe® grill and smoker (including, but not limited to the thermometer, gaskets, and iKamand controllers) or any Kamado Joe accessories are free of defects in material and workmanship for a period of two (2) years.

When Does the Warranty Coverage Begin?

Warranty coverage commences on the original date of purchase and covers only the original purchaser. For the warranty to apply, you must register your Kamado Joe® product using the product registration page on our website. If you discover a defect in material or workmanship during the applicable warranty period under normal use and maintenance, Kamado Joe® will, at our sole option, replace or repair the defective component at no cost to you for the component itself. This warranty does not apply to labor, or any other cost associated with the service, repair or operation of the grill. Kamado Joe will pay all shipping charges on warranty parts.

AUSTRALIA AND NEW ZEALAND RESIDENTS ONLY: Our goods come with guarantees that cannot be excluded under the Australian or New Zealand Consumer Law. You are entitled to a replacement or refund for a major failure and compensation for any other reasonably foreseeable loss or damage. You are also entitled to have the goods repaired or replaced if the goods fail to be of acceptable quality and the failure does not amount to a major failure.

What is Not Covered?

This warranty does not apply to damage caused by abuse or use of the product for purposes other than that for which it is designed, damage caused by lack of proper use, assembly, maintenance or installation, damages caused by accidents or natural disasters, damage caused by unauthorized attachments or modifications, or damage during transport. This warranty does not cover damage from normal wear and tear from use of the product (for example, scratches, dents, dings and chipping) or changes in the appearance of the grill that do not affect its performance.

THIS LIMITED WARRANTY IS EXCLUSIVE AND IN LIEU OF ANY OTHER WARRANTY, WRITTEN OR ORAL, EXPRESS OR IMPLIED, INCLUDING BUT NOT LIMITED TO THE WARRANTY OF MERCHANTABILITY OR FITNESS FOR A PARTICULAR PURPOSE. THE DURATION OF ANY IMPLIED WARRANTIES, INCLUDING ANY IMPLIED WARRANTY OF MERCHANTABILITY OR FITNESS FOR A PARTICULAR PURPOSE IS EXPRESSLY LIMITED TO THE DURATION OF THE WARRANTY PERIOD FOR THE APPLICABLE COMPONENT.

THE PURCHASER'S EXCLUSIVE REMEDY FOR BREACH OF THIS LIMITED WARRANTY OR OF ANY IMPLIED WARRANTY SHALL BE LIMITED AS SPECIFIED HEREIN TO REPLACEMENT. IN NO CASE SHALL KAMADO JOE® BE LIABLE FOR ANY SPECIAL, INCIDENTAL OR CONSEQUENTIAL DAMAGES.

This warranty is provided to you in addition to all rights and remedies conveyed to you by consumer protection laws and regulations. This warranty in no way affects your legal rights under statutory warranty regulations in your state or country of residence. Depending on your state or country of residence limitations on the length of an implied warranty or the damages available to you might not be limited by this warranty.

What Will Void the Warranty?

Purchasing any Kamado Joe® product through an unauthorized dealer voids the warranty. An unauthorized dealer is defined as any retailer who has not been expressly granted permission by Kamado Joe® to sell Kamado Joe® products.

NEED ASSISTANCE? CONTACT US

Our warranty terms may change from time to time. For an updated version of our warranty, visit www.kamadojoe.com/pages/warranty. For assistance or to request an updated copy of our warranty, contact us at the below.

North America

Kamado Joe ®
Premier Specialty Brands, LLC
5367 New Peachtree Road, Suite 150
Chamblee, GA 30341

<https://www.kamadojoe.com/pages/support>

United Kingdom

Kamado Joe UK Limited
Cheyenne House West Street
Farnham GU9 7EQ

<https://international.kamadojoe.com/pages/support>

Australia & New Zealand

Please contact your retailer.

European Union

Kamado Joe Europe
Lange Voorhout 86, 2514 EJ
Den Haag, Netherlands

<https://international.kamadojoe.com/pages/support>

KAMADOJOE®