

# OWNER'S MANUAL



## Competition Pro™

**Model #8125**

**Keep your receipt with  
this manual for Warranty.**

**CUSTOMER SERVICE  
1-912-638-4724  
Service@CharGriller.com**

Contents of this manual are Trademarked and Copyrighted by Char-Griller | A&J Manufacturing.  
Using the information contained in this manual without consent of Char-Griller and/or A&J  
Manufacturing is strictly prohibited.

**This Page Intentionally  
Left Blank**

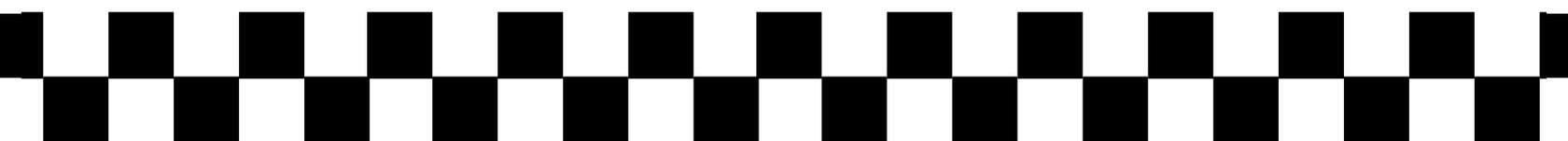



# TABLE OF CONTENTS

Safety Warnings & Warranty.....	A-1
Assembly Instructions .....	B-1
Product Usage .....	C-1
Recipes .....	D-1
Accessories .....	E-1

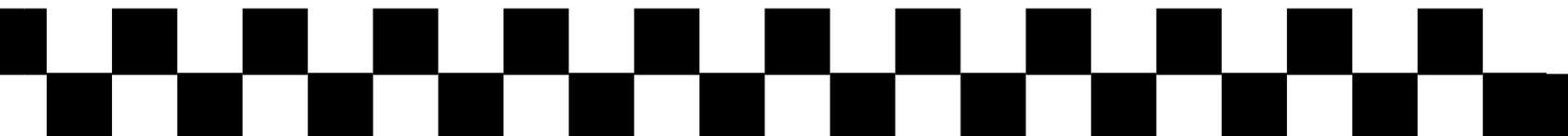

# IMPORTANT SAFETY WARNINGS

READ ALL SAFETY WARNINGS AND INSTRUCTIONS CAREFULLY BEFORE ASSEMBLING AND OPERATING YOUR GRILL

Read the following instructions carefully and be sure your appliance is properly assembled, installed, and maintained. Failure to follow these instructions may result in serious bodily injury and/or property damage. If you have any questions concerning assembly or operation, call 912-638-4724.

- Grill is for use outdoors and in well-ventilated areas, only.
- Use caution when assembling and operating your grill to avoid scrapes or cuts from sharp edges.
- Do not use gasoline, kerosene, or alcohol to light charcoal. Use of any of these or similar products could cause an explosion possibly leading to severe bodily injury.
- Do not leave a lit grill unattended. Keep children and pets away from grill at all times.
- Use caution when moving grill to prevent strains.
- Keep grill at least 15 feet from any combustible material (decks, buildings, fences, trees, bushes, etc).
- When adding charcoal and/or wood, use extreme caution.
- Never move grill when it is in use or when it contains hot coals or ashes.
- Do not place grill near flammable liquids, gases, or where flammable vapors may be present.
- Use caution since flames can flare-up when fresh air suddenly comes in contact with fire.
- When opening the lid, keep hands, face, and body safe from hot steam and flame flare-ups.
- WARNING: To avoid injuries, gloves or other protective articles should be used when touching the ash pan hangers.
- Do not exceed a temperature of 400°F.
- Do not allow charcoal and/ or wood to rest on the walls of grill. Doing so will greatly reduce the life of the grill.
- Always wear grill gloves to protect hands from burns. Avoid touching hot surfaces.
- CAUTION: Exposed metal dampers on air vents and/or metal handles are hot during usage. Again, always wear grill gloves when adjusting air flow to protect hands from burns.



**WARNING:** FUELS USED IN WOOD OR CHARCOAL BURNING APPLIANCES, AND THE PRODUCTS OF COMBUSTION OF SUCH FUELS, CAN EXPOSE YOU TO CHEMICALS INCLUDING CARBON BLACK, WHICH IS KNOWN TO THE STATE OF CALIFORNIA TO CAUSE CANCER, AND CARBON MONOXIDE, WHICH IS KNOWN TO THE STATE OF CALIFORNIA TO CAUSE BIRTH DEFECTS OR OTHER REPRODUCTIVE HARM. *For more information go to:* [www.P65Warnings.ca.gov](http://www.P65Warnings.ca.gov).

**ADVERTENCIA:** LOS COMBUSTIBLES USADOS EN EQUIPOS PARA QUEMAR MADERA O CARBÓN, ASÍ COMO LOS PRODUCTOS DE TAL COMBUSTIÓN, PUEDEN EXPONERTE A SUSTANCIAS QUÍMICAS, ENTRE ELLAS EL NEGRO DE HUMO Y EL MONÓXIDO DE CARBONO, QUE EL ESTADO DE CALIFORNIA RECONOCE COMO CAUSA, RESPECTIVAMENTE, DE CÁNCER Y DE MALFORMACIONES CONGÉNITAS Y OTROS DAÑOS AL SISTEMA REPRODUCTOR. *Para más información, visite [www.P65Warnings.ca.gov](http://www.P65Warnings.ca.gov)*



# **IMPORTANT SAFETY WARNINGS**

## **(Continued)**

- When opening lid, make sure it is pushed all the way back so it rests against the lid support brackets. Use extreme caution as hood could fall back to a closed position and cause bodily injury.
- Close lid and all dampers to help suffocate flame.
- Always hold an open lid from the handle to prevent it from closing unexpectedly.
- Never leave coals and ashes unattended. Before grill can be left unattended, coals and ashes must be removed. Use caution to protect yourself and property.
- Carefully place remaining coals and ashes in a noncombustible metal container and saturate completely with water. Allow coals and water to remain in a metal container for 24 hours prior to disposing.
- To protect against bacteria that could cause illness, keep all meats refrigerated and thaw in refrigerator or microwave. Keep raw meats separate from other foods, and wash everything that comes in contact with raw meat.
- Cook meat thoroughly, and refrigerate leftovers immediately.
- Use a calibrated food thermometer and the USDA guidelines to ensure that meat, poultry, seafood, and other cooked foods reach a safe minimum internal temperature.
- Always have a fire extinguisher near at all times. Maintain and check your fire extinguisher regularly.

**THESE WARNINGS ALSO APPLY TO THE SIDE FIRE BOX.**



## **REGISTER YOUR GRILL:**

To take full advantage of the Char-Griller warranty be sure to register your grill by visiting [www.CharGriller.com/Register](http://www.CharGriller.com/Register) or calling Customer Service at **1-912-638-4724**.

Registration provides important protections:

1. In the extremely unlikely event of a product recall Char-Griller can easily contact you and rectify the issue.
2. If a warrantied part is broken or missing we can send you the needed parts promptly.

*NOTE:* You will need your model #, serial number, and a copy of the original sales receipt when registering.

## **STOP! CALL FIRST!**

### **Do NOT Return Product to Store.**

This grill has been made according to the highest of quality standards. If you have any questions that are not addressed in this manual or if you need parts please call our Customer Service Department at 1-912-638-4724 (USA) or email Char-Griller at: [Service@CharGriller.com](mailto:Service@CharGriller.com) and have your serial number handy.

### **Document Your Grill Model and Serial Numbers HERE:**

(Model and Serial number are located on the back of the grill body or on the leg.)

\_\_\_\_\_

(MODEL #)

\_\_\_\_\_

(SERIAL #)

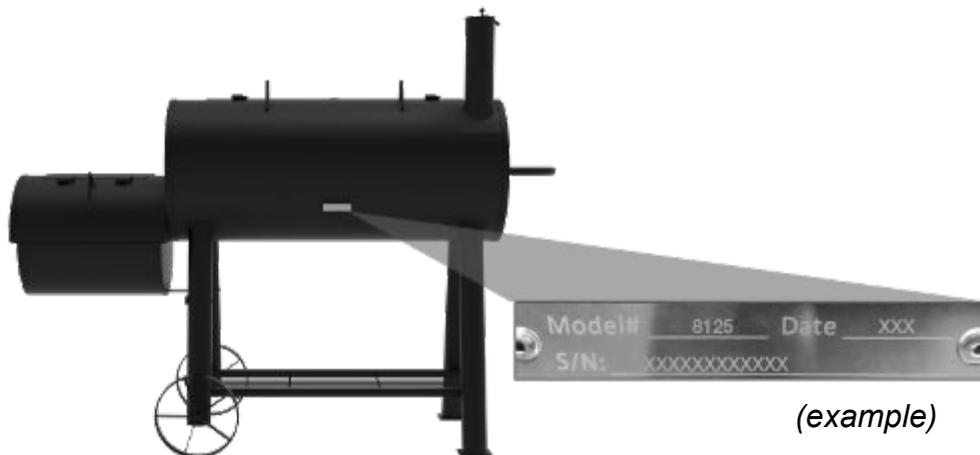

**IMPORTANT NOTICE:** Read all instructions carefully before assembly and use. Read and understand all warnings and precautions before operating your grill.



# WARRANTY INFORMATION

**A COPY OF THE DATED PROOF OF PURCHASE (RECEIPT) IS REQUIRED WHEN REGISTERING OR SUBMITTING A WARRANTY\* CLAIM. PLEASE RETAIN A COPY OF THE RECEIPT FOR YOUR RECORDS.**

Char-Griller will replace any defective part of its grillers/smokers, under warranty, as outlined below.

**PLEASE READ THIS INFORMATION IN DETAIL AND IF YOU HAVE ANY QUESTIONS CONTACT CUSTOMER SERVICE AT 912-638-4724 OR SERVICE@CHARGRILLER.COM.**

<b>Charcoal / Pellet / Kamado Grills</b>	
Grill - Hood AND Bottom (excludes removable Ash Pan)	5 years from date of purchase for rust through / burn through
Ash Pan AND Defective Parts	1 year from date of purchase
<b>Gas Grills</b>	
Grill Hood (TOP half) AND Main Burner Tubes (excludes Side Burner)	5 years from date of purchase for rust through / burn through
Grill Body (BOTTOM half) AND Side Burner AND Defective Parts	1 year from date of purchase
<b>Dual Fuel Grills (Gas &amp; Charcoal)</b>	
Charcoal Grill - Hood AND Bottom AND Gas Grill Hood (TOP half) AND Main Burner Tubes (excludes Ash Pan and Side Burner)	5 years from date of purchase for rust through / burn through
Ash Pan AND Defective Parts AND Gas Grill Body (BOTTOM half) AND Side Burner	1 year from date of purchase
<b>Parts, Accessories, and Grill Covers</b>	1 year from date of purchase (seam tears only for covers)

## **SURFACE RUST IS NOT CONSIDERED A MANUFACTURING OR MATERIALS DEFECT**

Char-Griller grills are made of steel and if exposed to the elements rust will occur naturally. Please refer to the section entitled, "Usage" to review how to care for your grill properly.

Surface issues such as scratches, dents, corrosion or discoloring by heat, abrasive and chemical clearers, surface rust or the discoloration of steel surfaces are NOT covered under these warranties.

Warranties are for the replacement of defective parts only. Char-Griller is not responsible for damage resulting from accident, alteration, misuse, abuse, hostile environments, improper installation, and installation not in accordance with local codes of service of unit.

### **Excluded Under ALL Warranties**

Paint; Surface Rust; Heat Damage; Incorrect Parts ordered by customer, including shipping; Worn Parts; Missing or damaged parts not reported within two (2) months of purchase date; Defective parts not reported within one (1) year of purchase date; Fading grill cover.

\*NOTE: For warranty claims, photos and prepaid return of the item in question may be required. Misuse, abuse or commercial use nullifies all warranties.







# PARTS LIST

Item	Part Name	QTY
1	THERMOMETER WITH WINGNUT & FLAT WASHER	1
2	LOGO PLATE W/CLIPS	1
3	HOOD HANDLE	1
4	LID	1
5	BODY	1
6	SIDE FIRE BOX (SFB) LID STOPPER	1
7	SFB HANDLE	1
8	SFB LID	1
9	SFB TOP HALF	1
10	SFB COOKING GRATE	2
11	SFB CHARCOAL GRATE	1
12	SFB BOTTOM HALF	1
13	SFB DOOR LATCH	1
14	SFB DOOR DAMPER	1
15	SFB SUPPORT BRACKET	1
16	WHEEL	2
17	SHORT LEG	2
18	AXLE ROD	1
19	BOTTOM SHELF	1
20	LONG LEG	2
21	UTENSIL HOOK	3
22	FRONT SHELF	1
23	CHARCOAL GRATE	3
24	COOKING GRATE	3
25	SIDE HANDLE	1
26	SMOKESTACK	1
27	SMOKESTACK DAMPER	1
28	SMOKESTACK SPRING	1
29	ACORN NUT	1

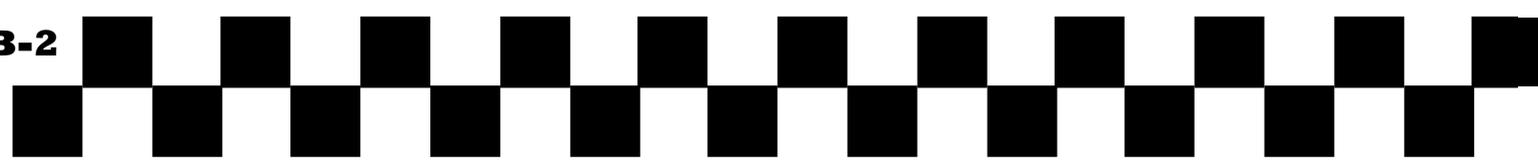

# HARDWARE AND TOOLS NEEDED

**Assembly:** Requires 2 people. Tools Needed: Pliers, Phillips Head Screwdriver and a 7/16" Nut Driver.

**NOTE:** Do Not tighten any bolts unless instructed to do so. Tightening too soon may prohibit parts from fitting together. All Hex Nuts should be on the inside of the grill unless stated otherwise. Unpack all contents in a well cleared and padded area.

**Estimated Assembly Time:** 45 minutes

**STOP! Do Not Return to Store.** If you are missing parts or need assistance please email us at [Service@CharGriller.com](mailto:Service@CharGriller.com) or call 912-638-4724. Do not attempt to assemble or use if you are missing parts.

## Hardware Pack: 551060

Part No.	Description	Photo	QTY
1	1/2" HEX BOLT		45
2	1/4-20 HEX FLANGE NUT		10
3	7/16" HEX JAM NUT		2
4	LOCK WASHER		32
5	FLAT WASHER		2
6	UTENSIL HOOK		3



# ASSEMBLY

## STEP 1

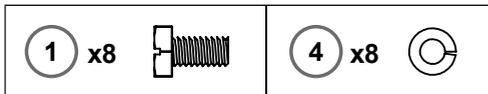

Attach one (1) LONG LEG and one (1) SHORT LEG to back leg positions on GRILL BODY underside, using eight (8) 1/4-20 x 1/2" HEX BOLTS and eight (8) 1/4 LOCK WASHERS.

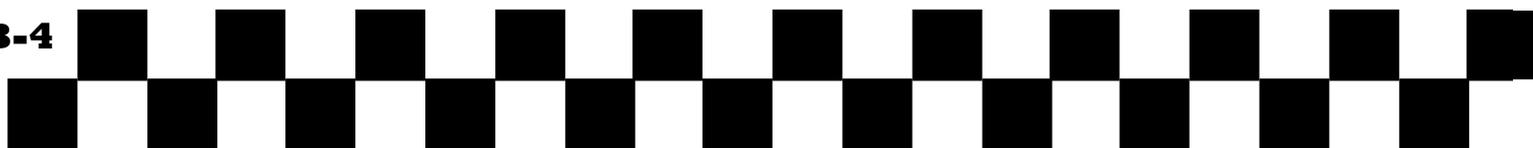
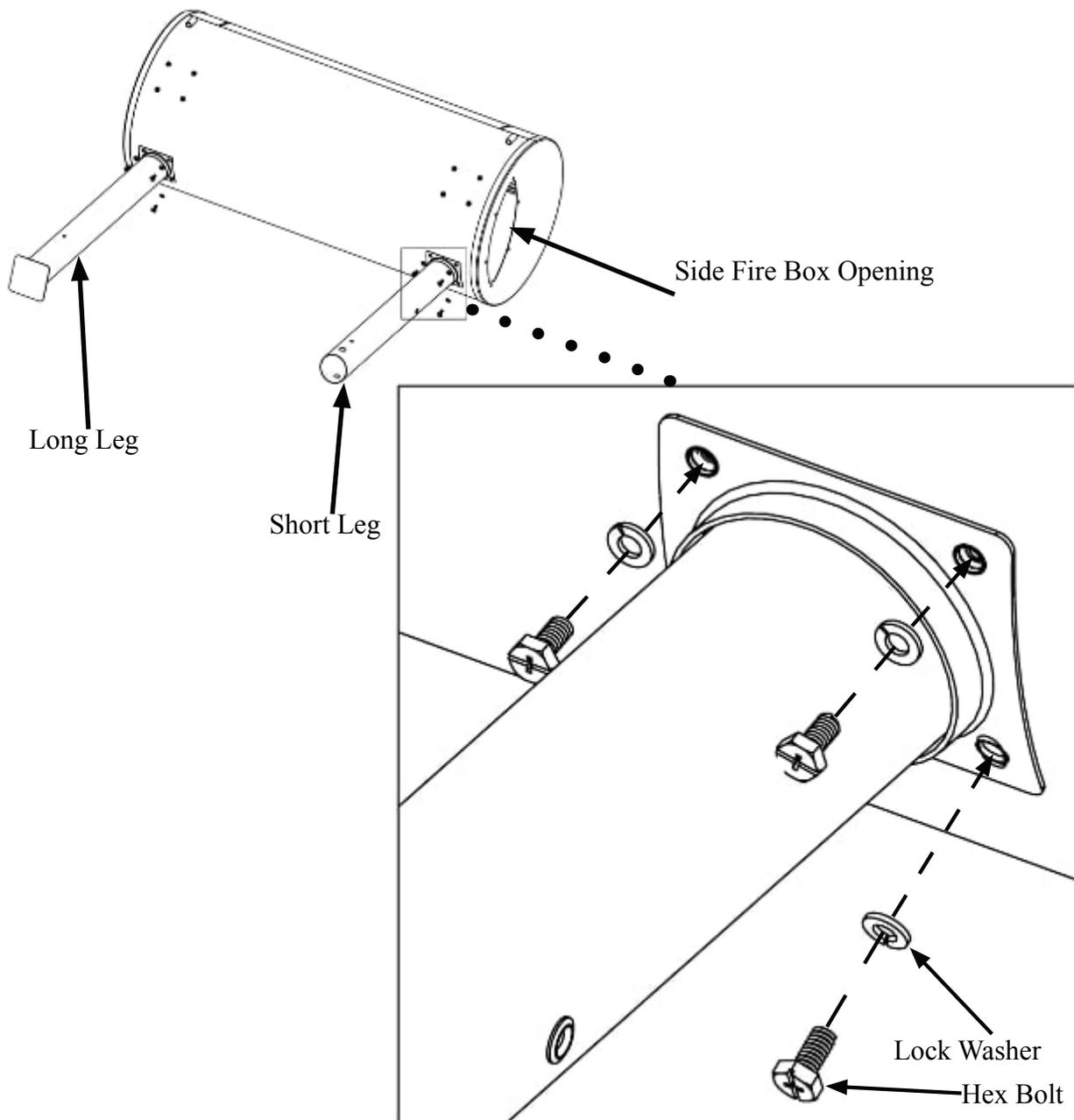

## STEP 2

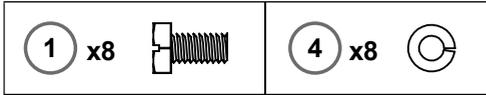

Attach remaining one (1) LONG LEG and one (1) SHORT LEG to front positions on GRILL BODY underside, using eight (8)  $\frac{1}{4}$ -20 x  $\frac{1}{2}$ " HEX BOLTS and eight (8)  $\frac{1}{4}$  LOCK WASHERS. Install the BOTTOM SHELF by sliding the hook on each corner of the bottom shelf into the hole on the legs, then tighten the bolts.

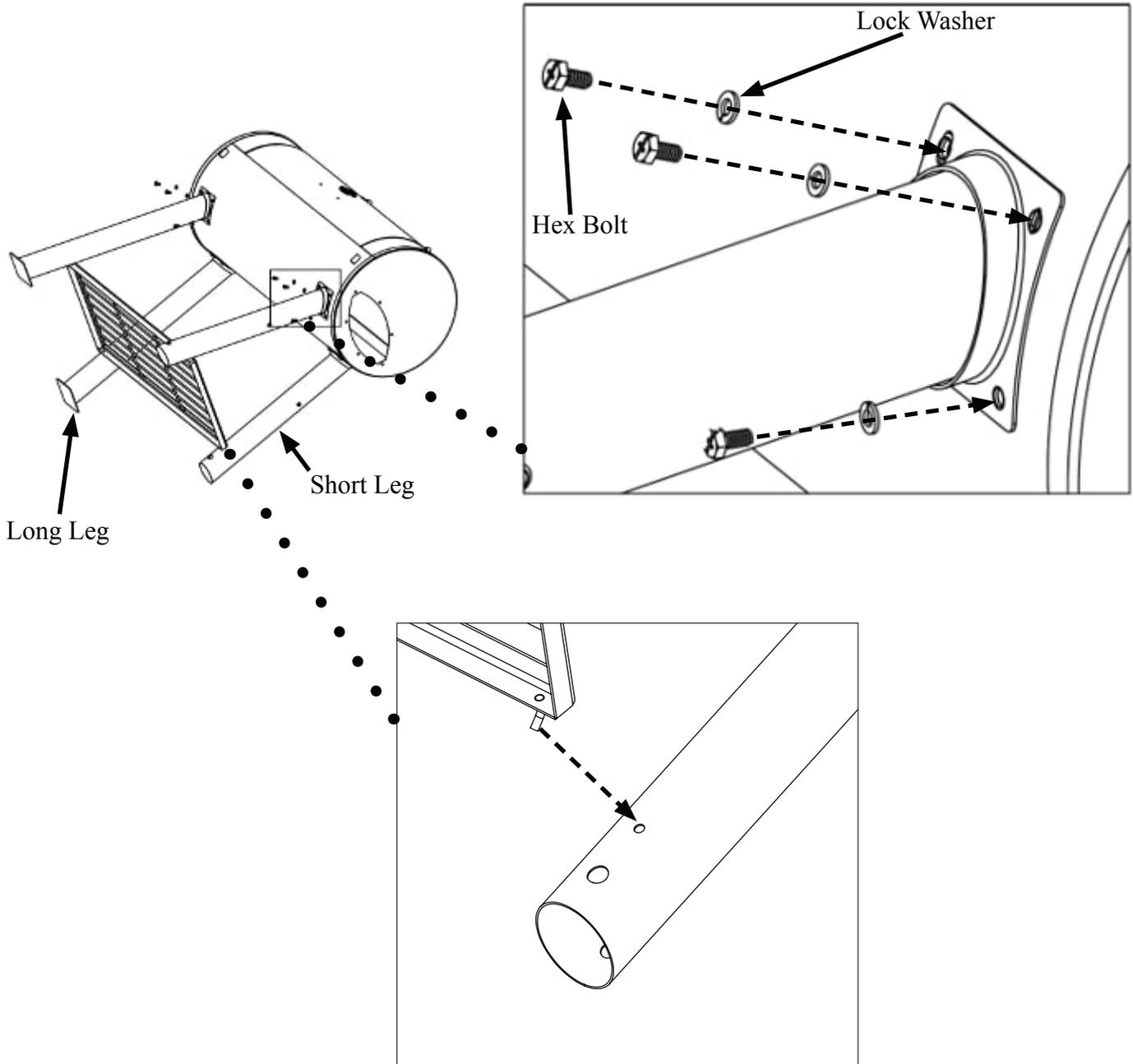



### STEP 3



Run AXLE ROD through holes in SHORT LEGS, then attach wheels to axle rod using two (2) 7/16" HEX JAM NUTS.

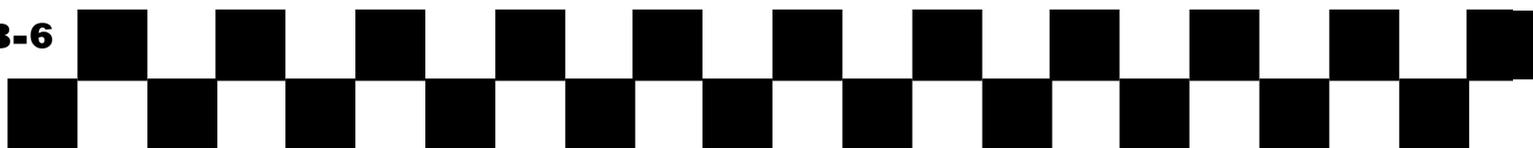
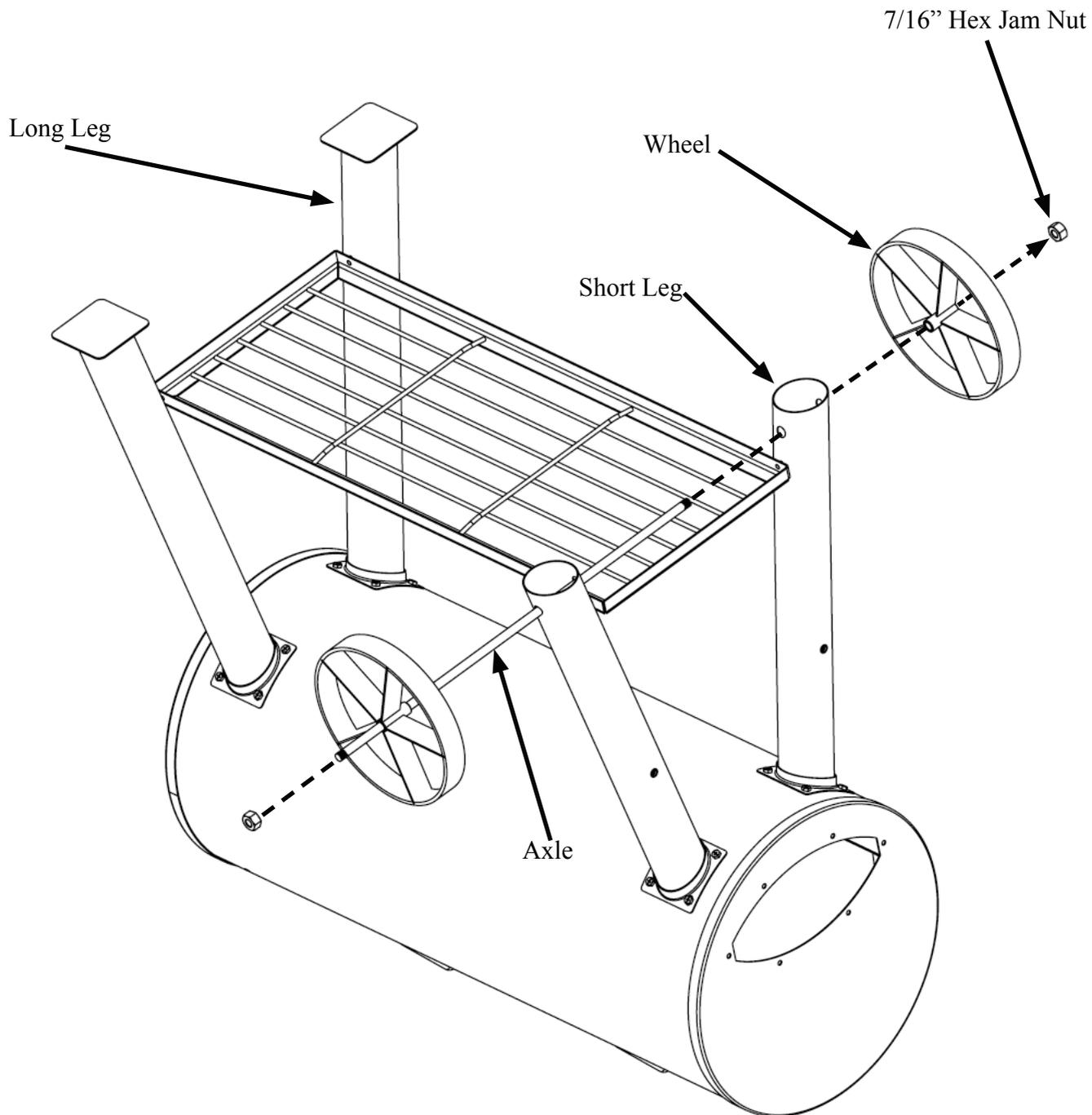

**STEP 4**

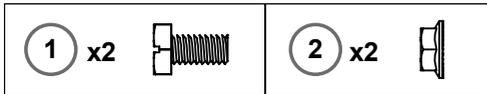

Attach HOOD HANDLE to GRILL HOOD using two (2) ¼-20 x ½" HEX BOLTS and two (2) ¼-20 HEX FLANGE NUTS.

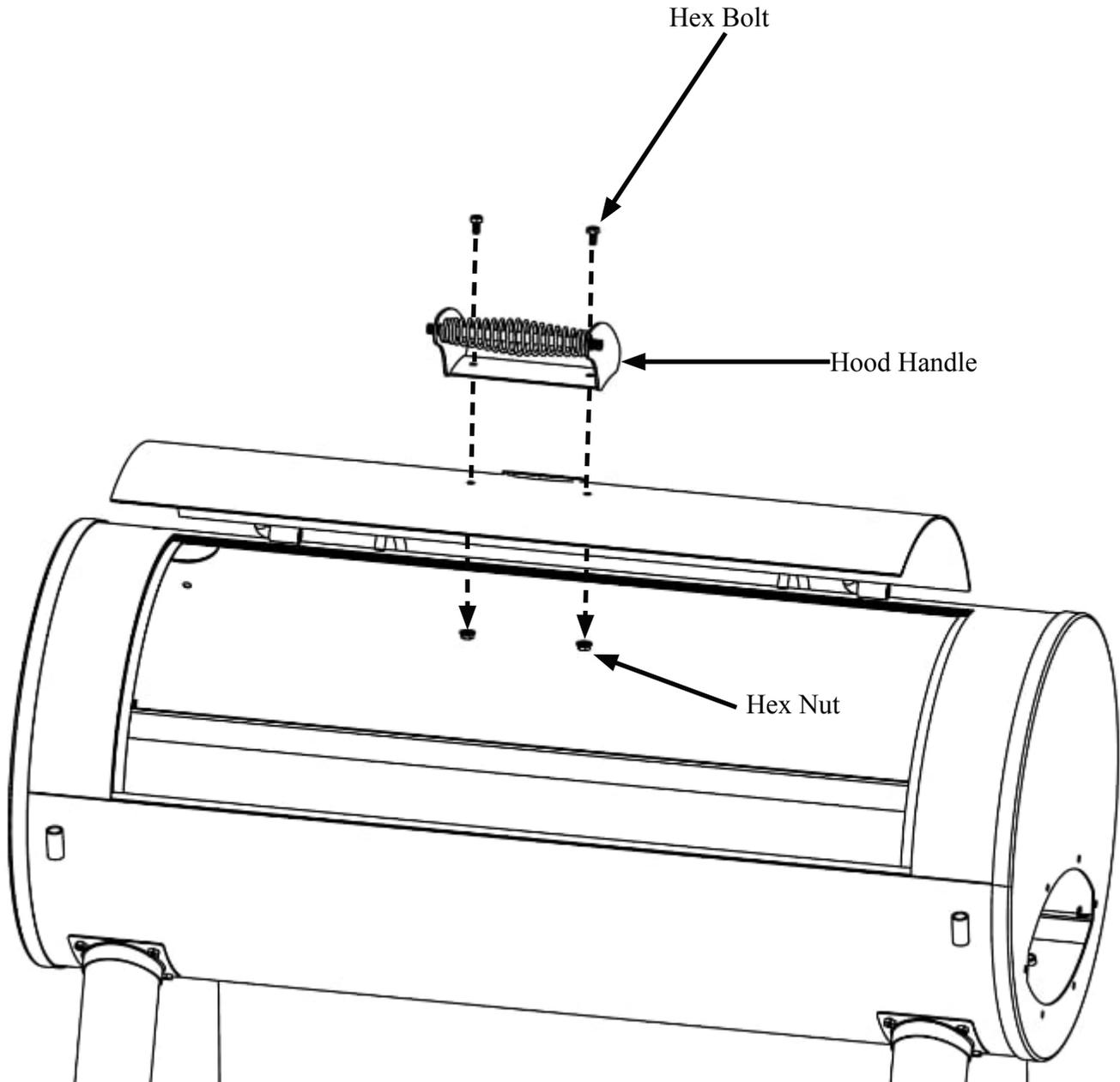



### STEP 5

Place THERMOMETER through hole in GRILL HOOD, and secure with included WINGNUT and FLAT WASHER, as shown. (NOTE: Hardware came attach on Thermometer.)

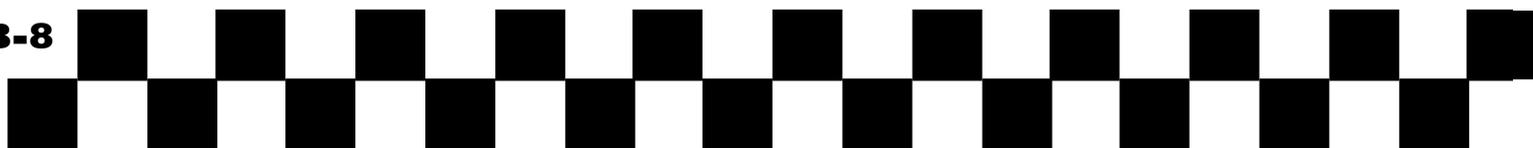
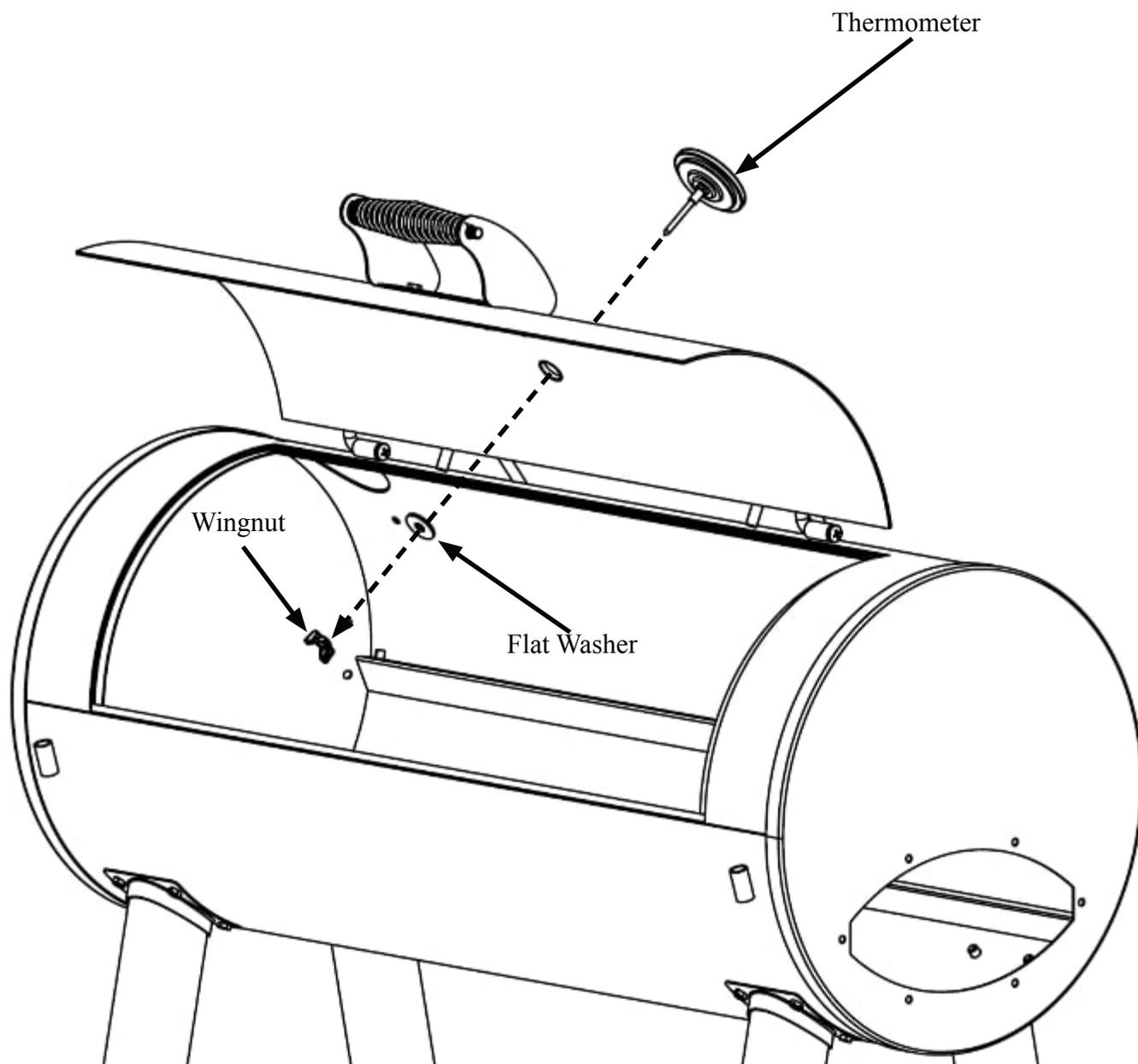

**STEP 6**

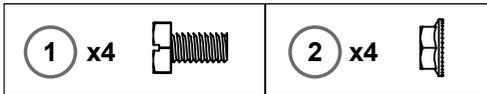

Attach SIDE HANDLE to GRILL BODY using four (4) 1/4-20 x 1/2" HEX BOLTS and four (4) 1/4-20 HEX FLANGE NUTS.

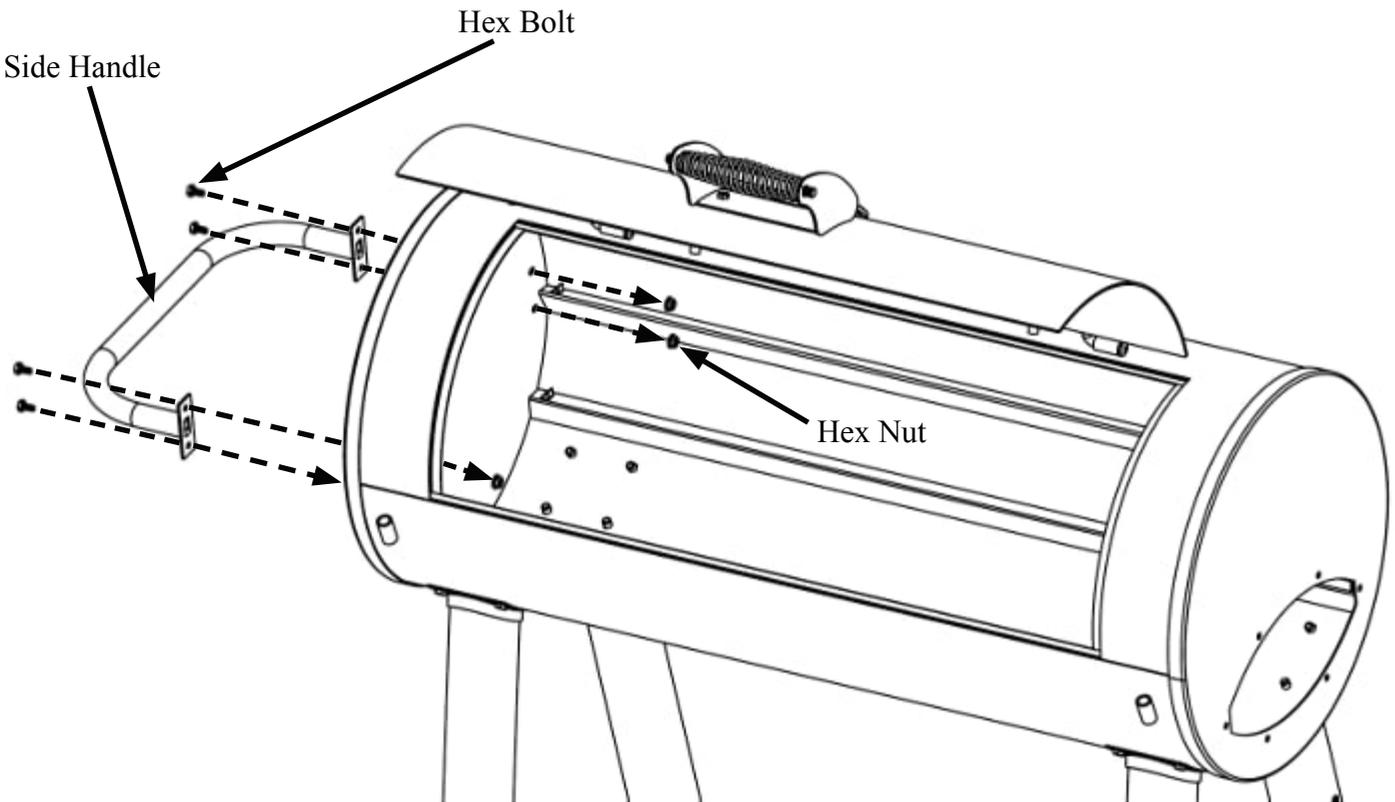



### STEP 7

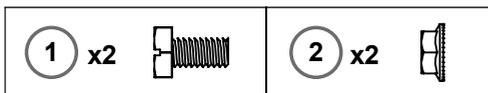

Attach SMOKESTACK to GRILL BODY using two (2) 1/4-20 x 1/2" HEX BOLTS and two (2) 1/4-20 HEX FLANGE NUTS.

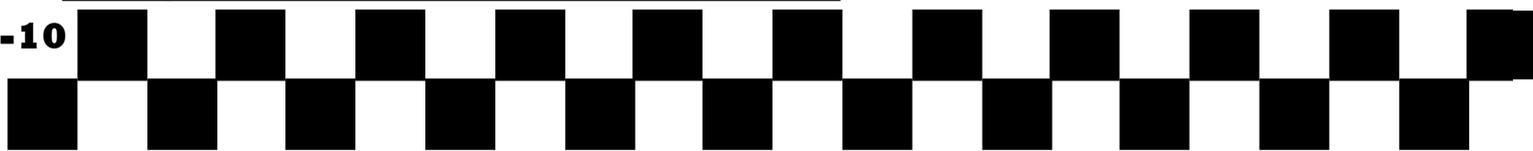
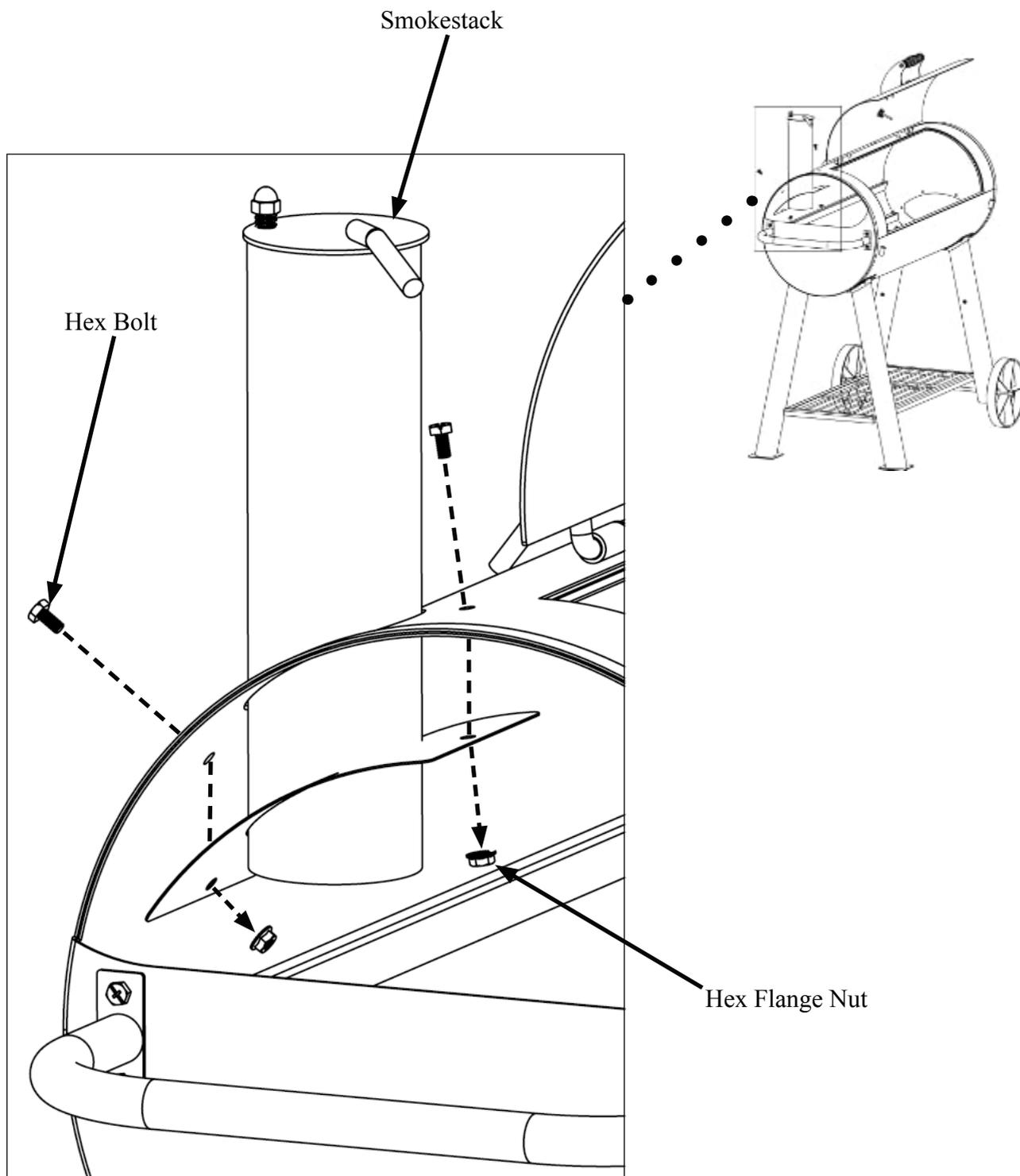

## STEP 8

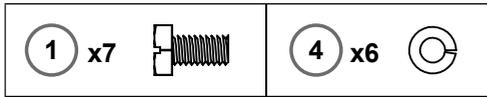

Attach TOP HALF OF SFB to BOTTOM HALF OF SFB using seven (7)  $\frac{1}{4}$ -20 x  $\frac{1}{2}$ " HEX BOLTS and six (6)  $\frac{1}{4}$  LOCK WASHERS.

Then, attach the LID STOPPER to the top of the SIDE FIRE BOX by inserting into lid and attaching with HEX BOLT.

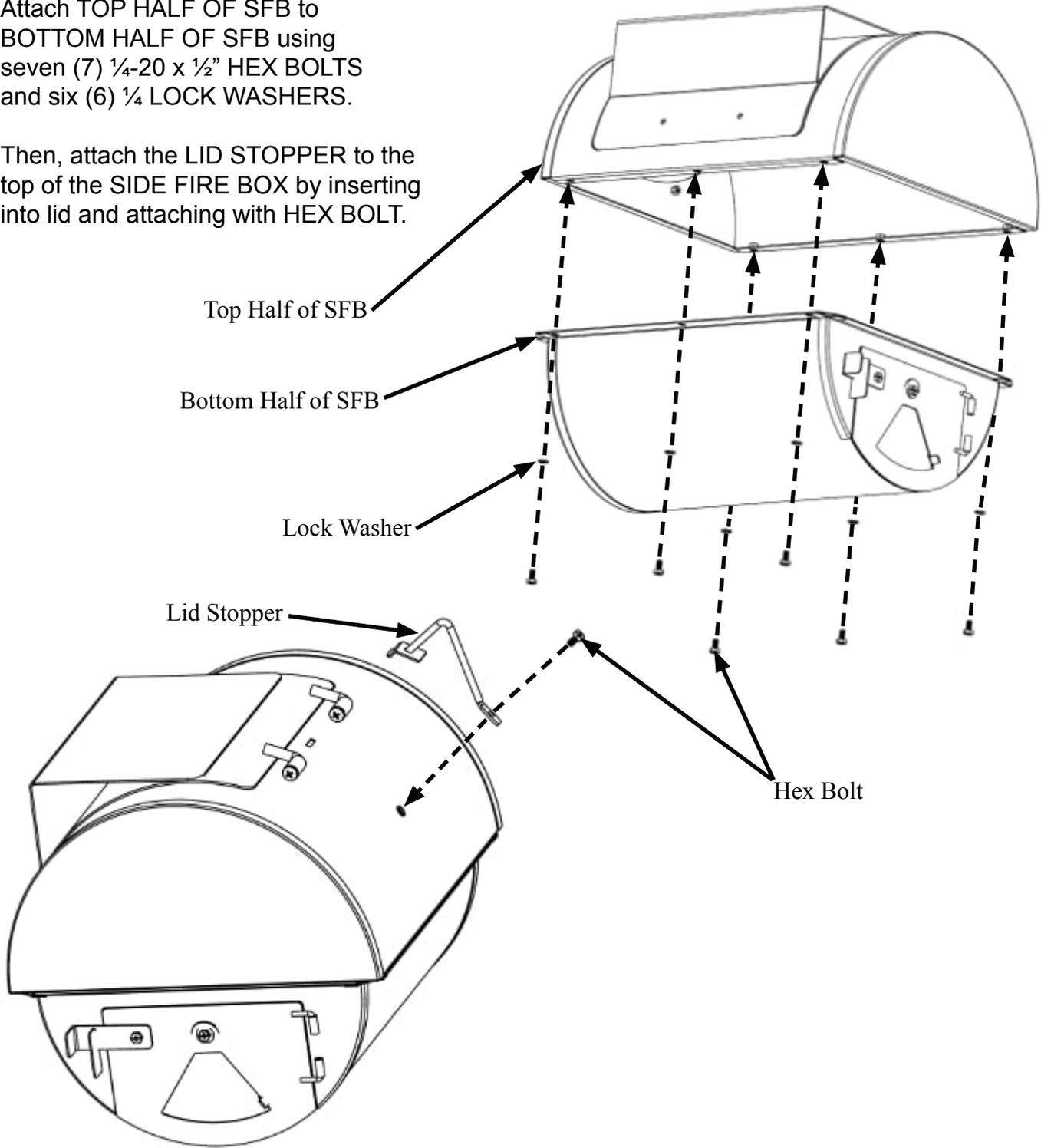



### STEP 9

 x4 	 x2 	 x2 
--	--	--

Attach SIDE FIRE BOX LID to SIDE FIRE BOX using two (2) 1/4" FLAT WASHERS and two (2) 1/4-20 x 1/2" HEX BOLTS.

Then attach HANDLE to SIDE FIRE BOX using two (2) 1/4-20 x 1/2" HEX BOLTS and two (2) 1/4-20 HEX FLANGE NUTS.

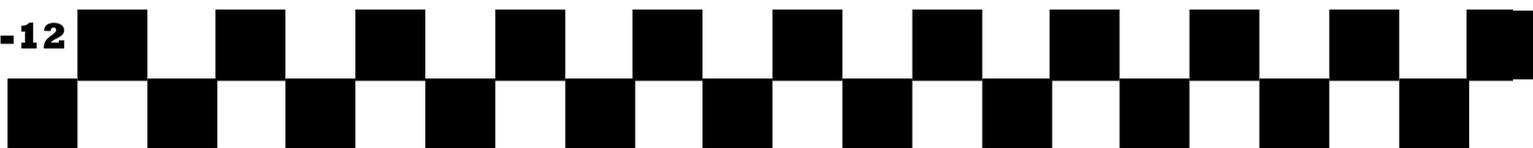
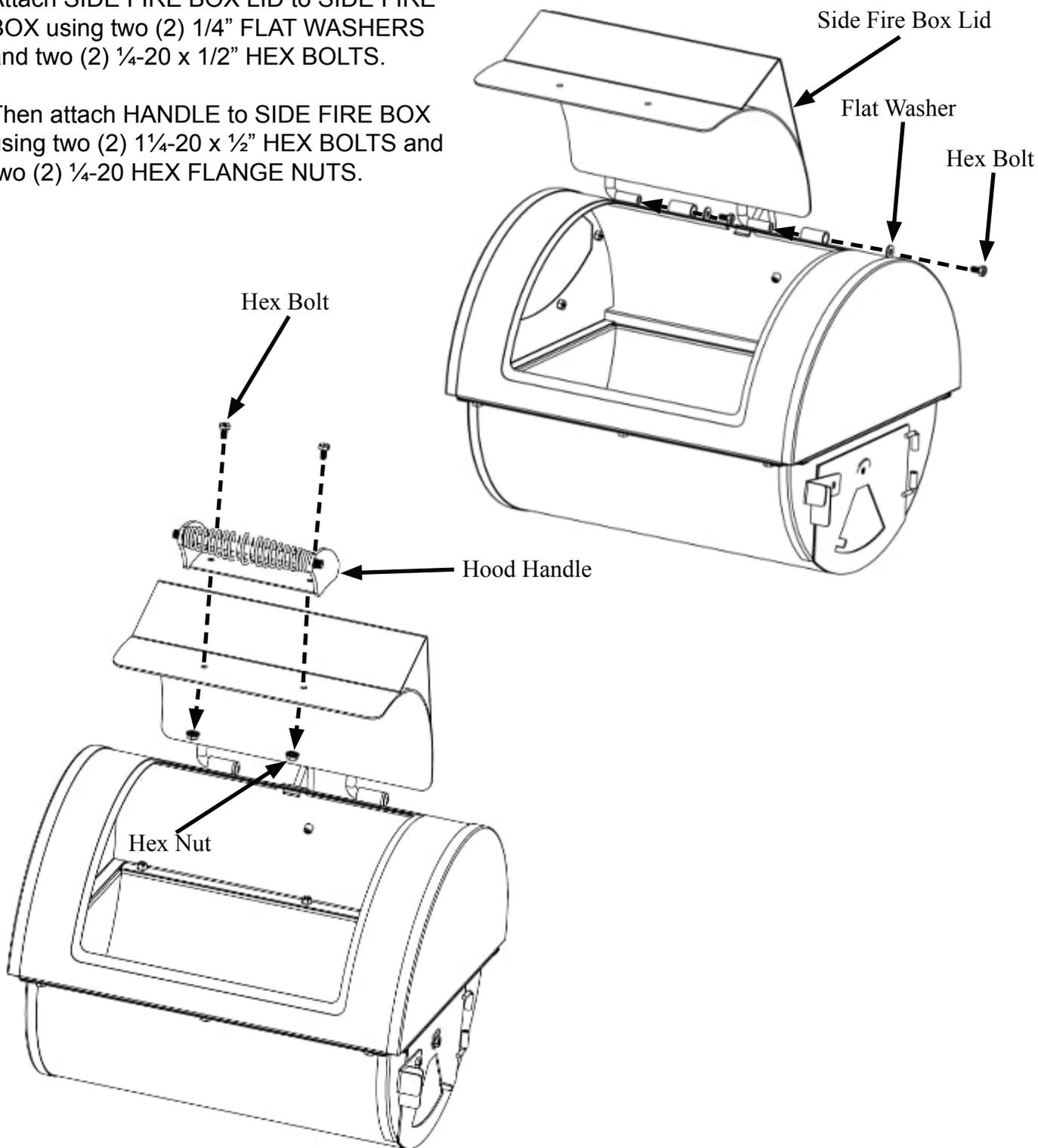

**STEP 10A**

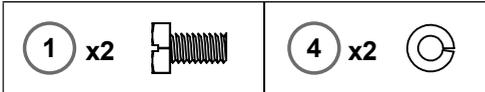

Attach SIDE FIRE BOX BRACE to GRILL using two (2) 1¼-20 x ½" HEX BOLTS and two (2) ¼" LOCK WASHERS.

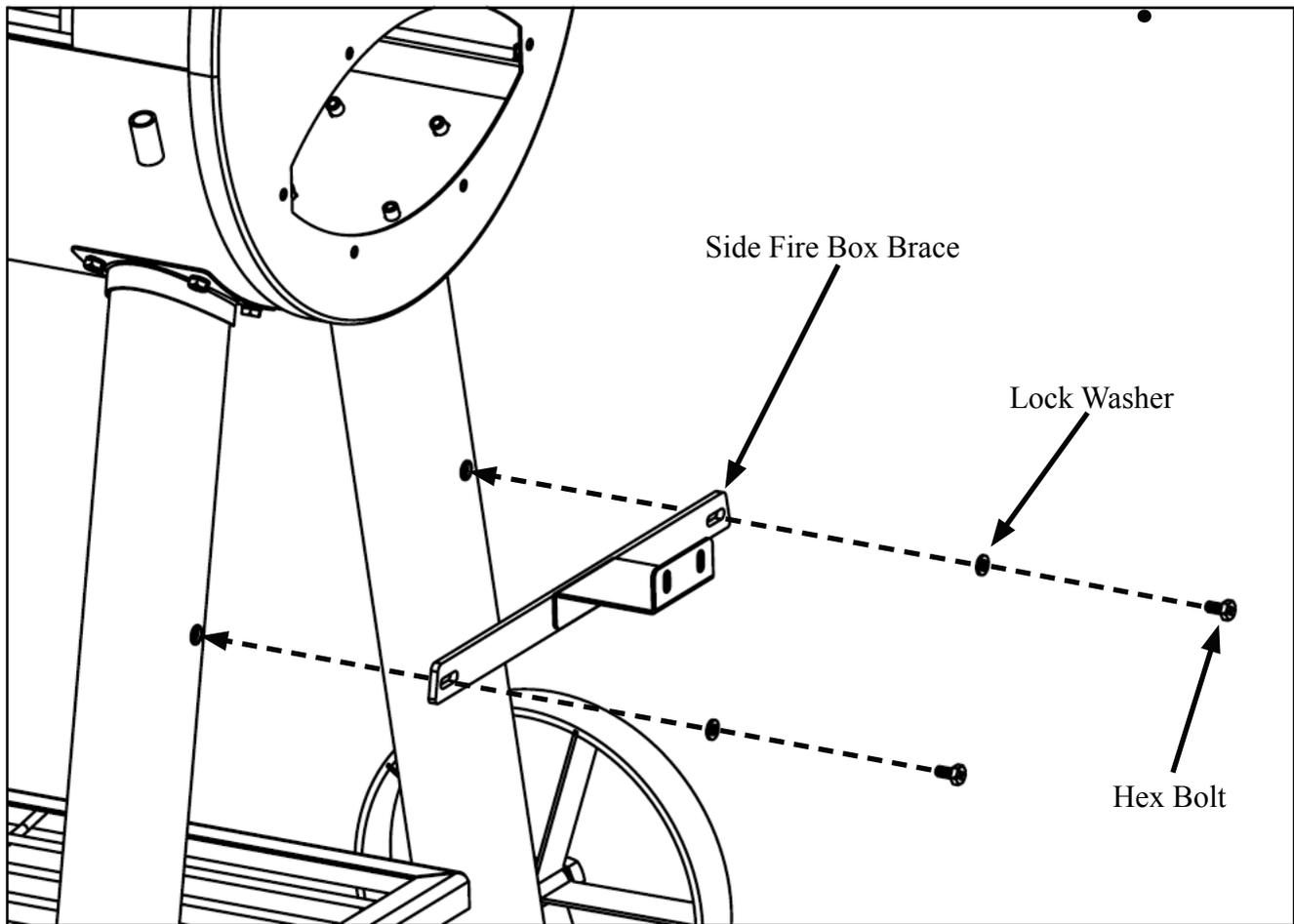
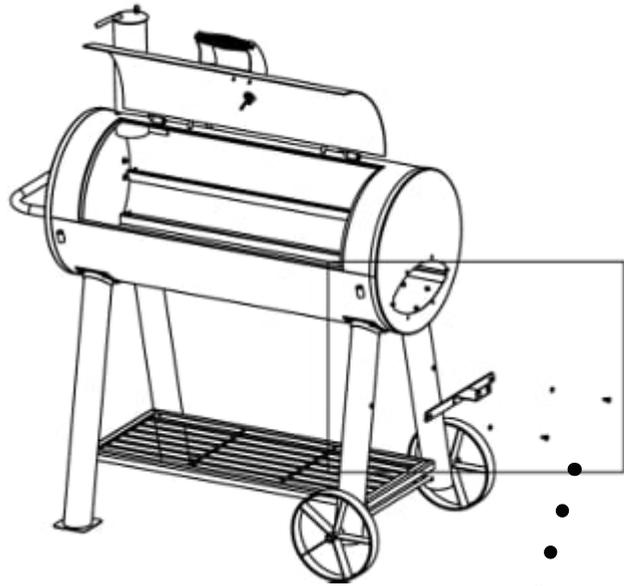

**STEP 10B**

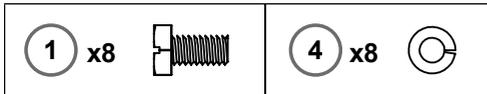

Attach SIDE FIRE BOX UNIT to GRILL using eight (8) 1¼-20 x ½" HEX BOLTS and eight (8) ¼" LOCK WASHERS.

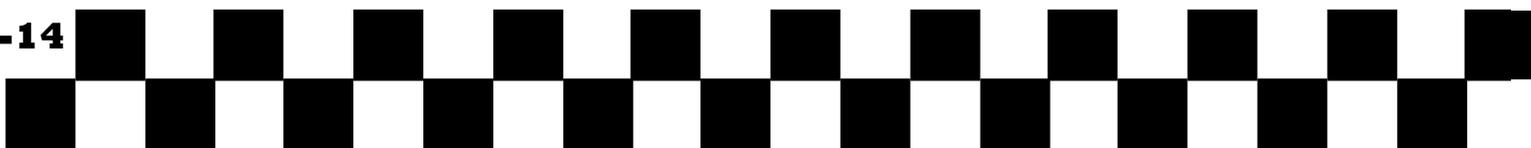
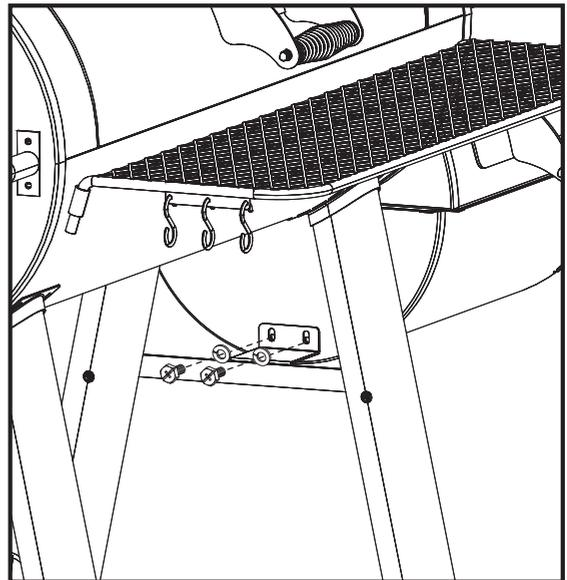
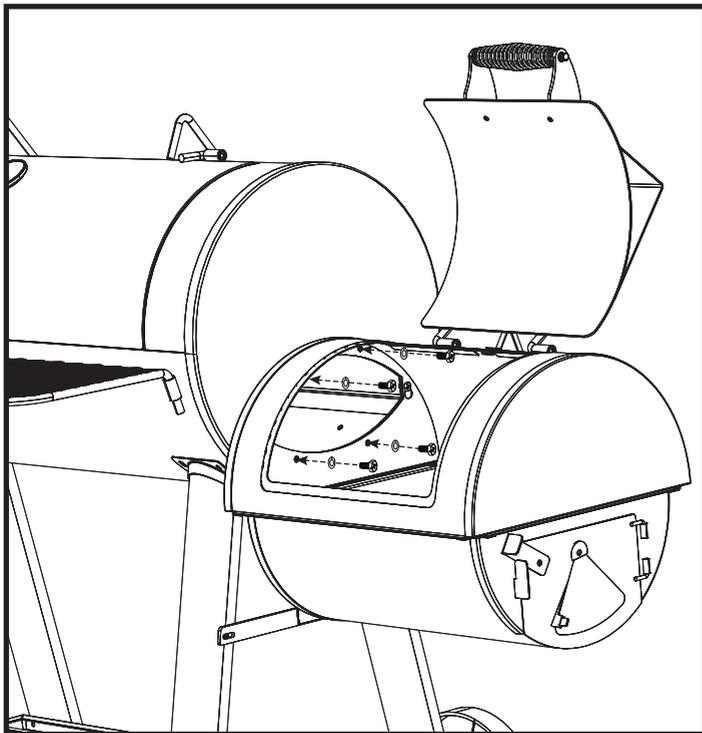
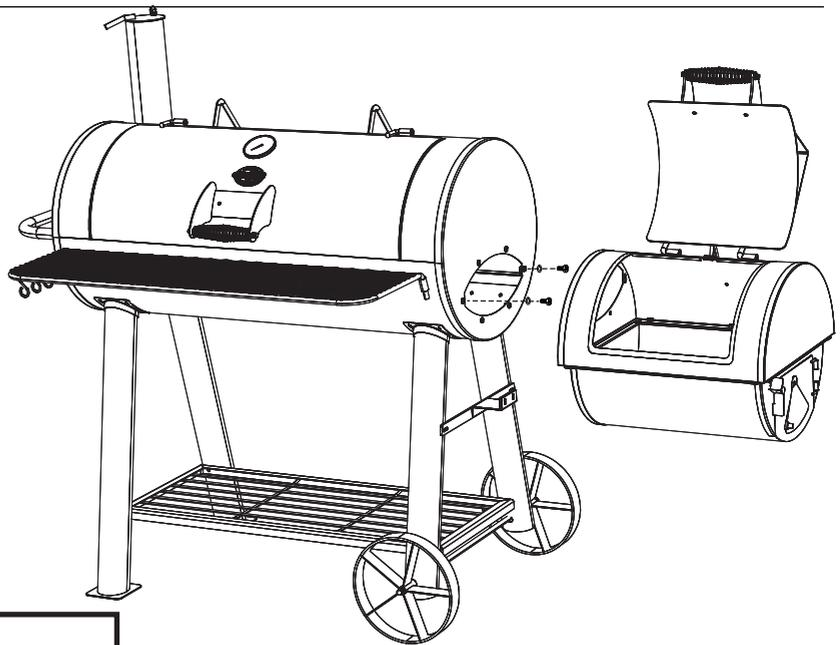

## STEP 11

---

Place CHARCOAL GRATES inside GRILL BODY near bottom, as shown.  
Then, place CHARCOAL GRATE inside SIDE FIRE BOX.

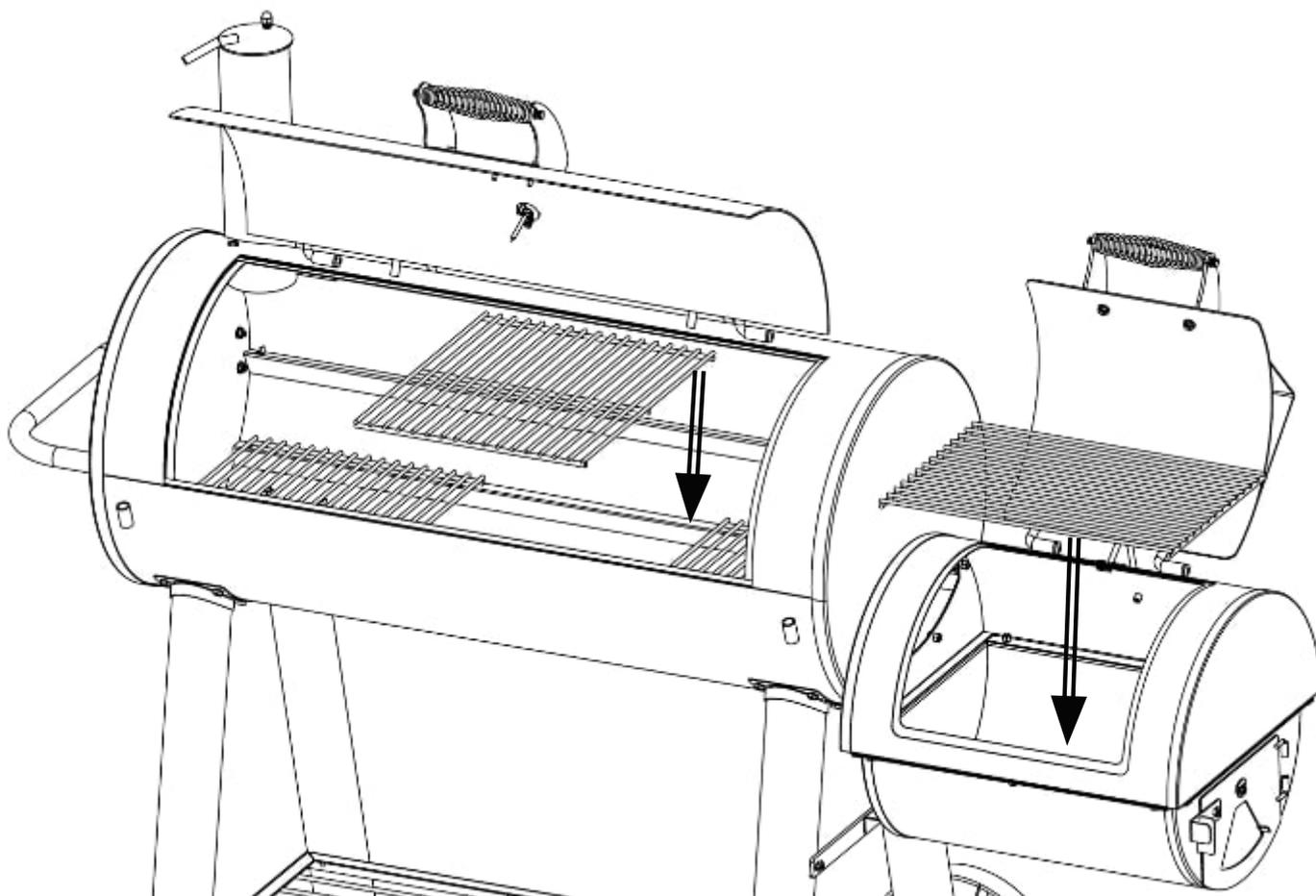



## STEP 12

---

Place COOKING GRATES inside GRILL BODY above CHARCOAL GRATES, as shown. Then, place COOKING GRATE inside SIDE FIRE BOX.

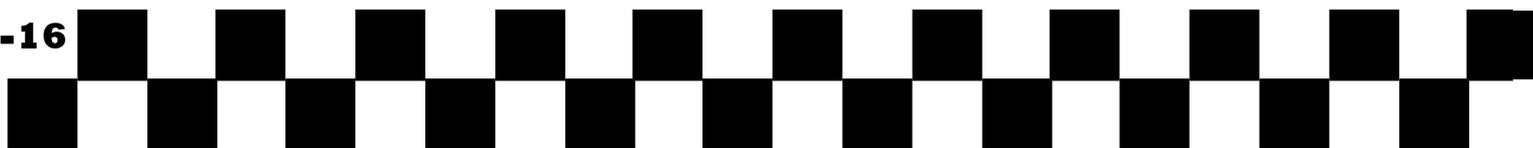
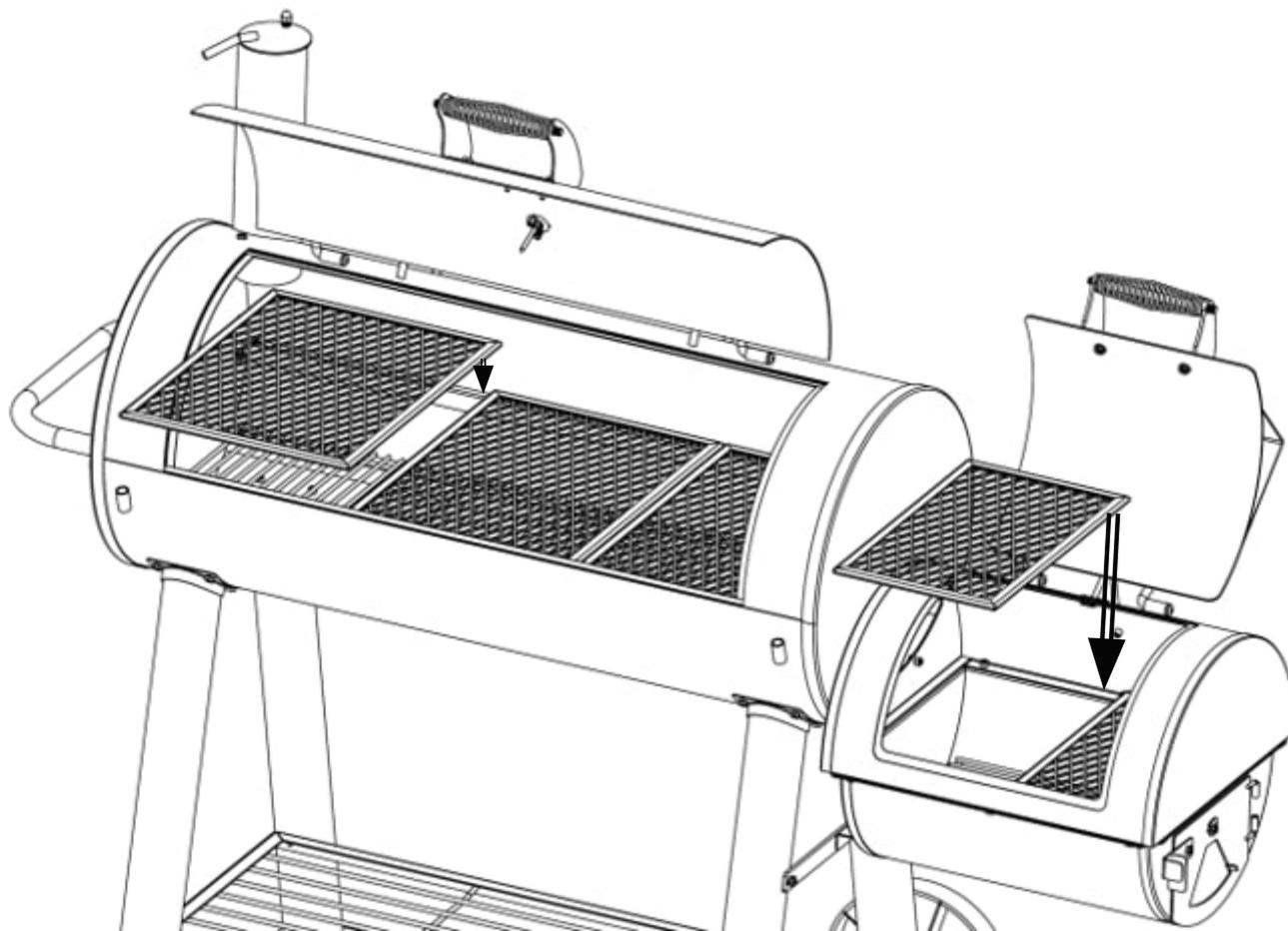

**STEP 13**

Attach FRONT SHELF to front of GRILL BODY, as shown.

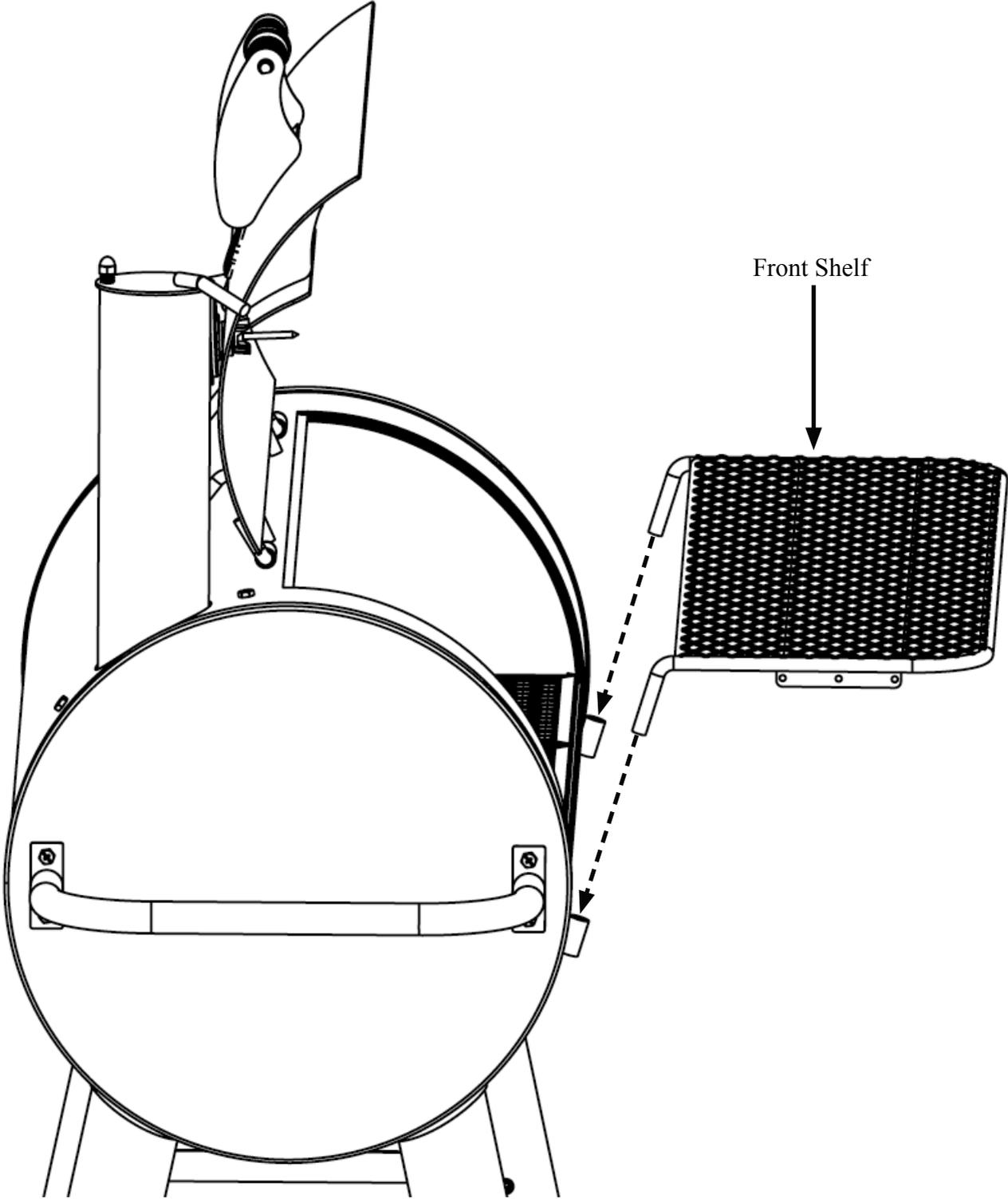



**STEP 14**



Attach UTENSIL HOOKS to FRONT SHELF, as shown.

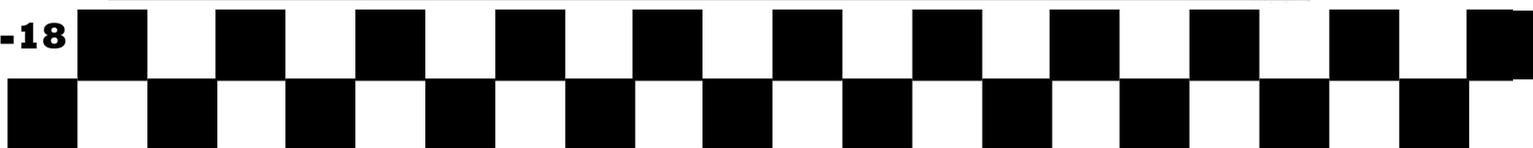
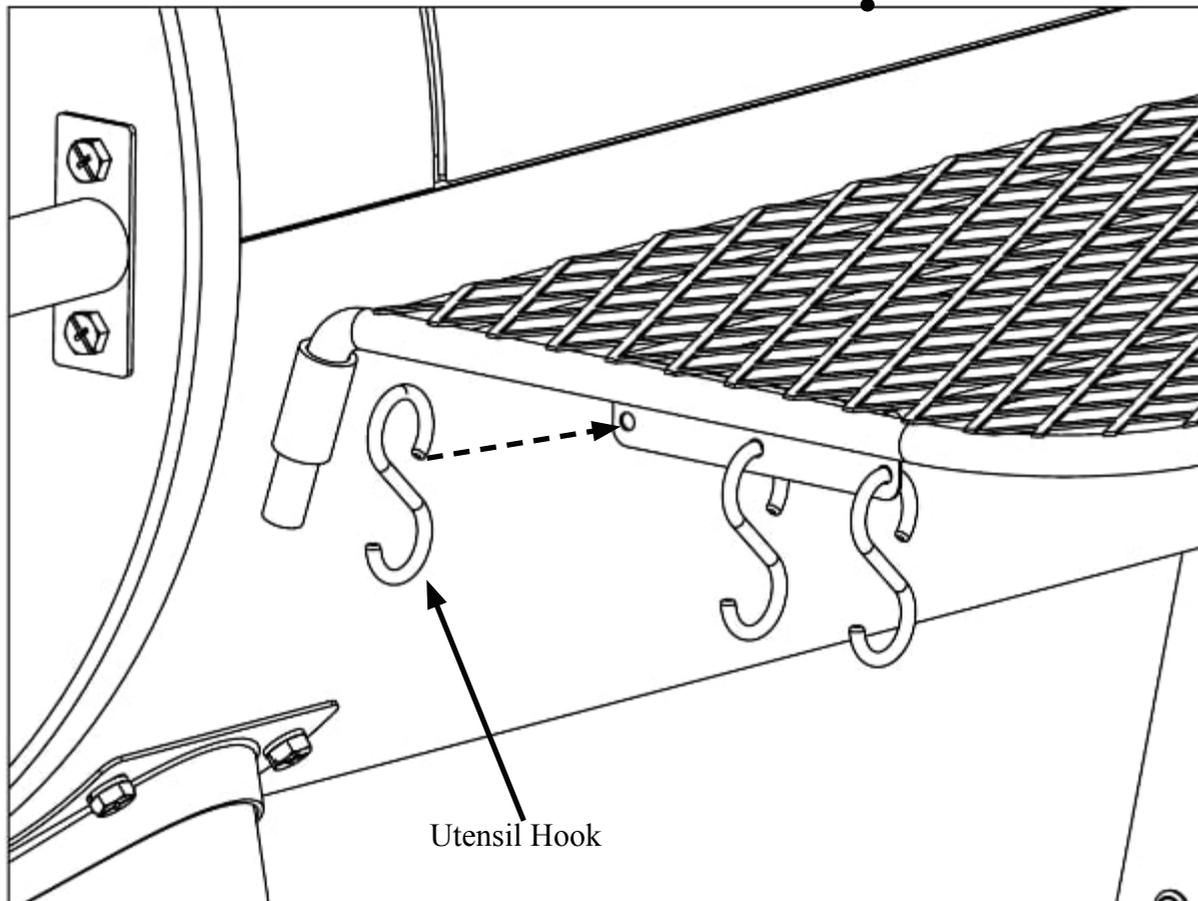
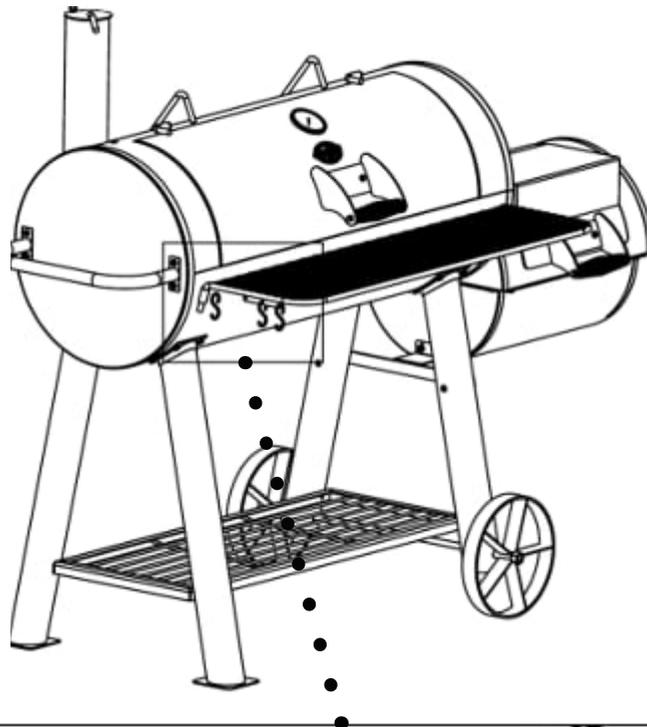

## Fully Assembled



**Hint:** The paper label that is affixed to the hood is more easily removed when the hood is warm. Any remaining glue residue can be cleaned off with a spray lubricant like WD-40 . Do NOT use any other type of solvent or cleaner because this will damage the finish/paint/coating on the grill.



**This Page Intentionally  
Left Blank**

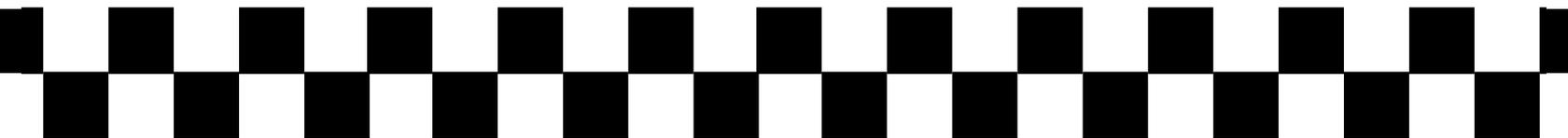

# OPERATING INSTRUCTIONS

## Setting Up

This appliance is designed for use outdoors, away from any flammable materials. It is important that there are no overhead obstructions and that there is a minimum distance of 36 inches (90 cm) from the side or rear of the appliance. It is important that the ventilation openings of the appliance are not obstructed.

The grill must be used on a level, stable surface. The appliance should be protected from direct drafts and positioned or protected against direct penetration by any trickling water (e.g. rain). Do not move grill while hot, and do not leave unattended during operation

**\*\* PLEASE NOTE: NO RETURNS ON USED GRILLS \*\***

## Seasoning and Preparing the Grill

**IMPORTANT: BEFORE YOU USE YOUR GRILL FOR THE FIRST TIME YOU MUST SEASON THE CAST IRON COOKING GRATE(S).**

Cure grill prior to your initial use to protect the interior and exterior finish, cooking grates, and to prevent unnatural flavors to your first meals.

1. Lightly coat ALL INTERIOR SURFACES (including grills, grates, and inside of barrel) with vegetable oil (spray vegetable oil is easiest but do not use near hot coals or fire).
2. Stack 50-60 briquettes in a pyramid on the **fire grate**. Always put charcoal on top of the fire grate and not directly into the bottom of the grill.
3. After coals ash over, spread out coals, replace cooking grates, close lid and heat at approximately 250° F for two hours.
4. Remove grates from the grill with grill gloves, allow to cool, then re-coat grates and return to grill at approximately 200° F for two hours.
5. You can lightly coat the exterior of the grill body (while warm) with vegetable oil. This will extend the life of the finish, much like waxing a car. Your grill is now ready for use.

**NOTE: Grill will drip oil during this process and for several uses afterwards.  
This is normal.**

NEVER EXCEED 400°F BECAUSE THIS WILL DAMAGE THE FINISH AND CONTRIBUTE TO RUST. PAINT IS NOT WARRANTED AND WILL REQUIRE TOUCH-UP. THIS UNIT IS NOT WARRANTED AGAINST RUST.



## Lighting Instructions

1. To start a charcoal fire, stack 50-60 briquettes in a pyramid. Place fire starter in the middle of the briquettes and light the fire starter. **NOTE:** Do not use gasoline, kerosene or alcohol for lighting charcoal. Use of any of these or similar products could cause an explosion possibly leading to severe bodily injury.
2. After briquettes ash over or turn gray, spread them out and start cooking.
3. If necessary, use tongs to move coals for even heat.

## Grill Operation & Tips

- Control heat with amount and type of fuel, dual dampers, and adjustable fire grate. Adjust fire grate one end at a time. Wood burns hotter than coals. More airflow helps generate more heat.
- To reduce flare-ups, cook with lid closed and in the down position.
- Add water soaked hardwood chips for a smoked flavor.
- Ashes left in grill too long between uses will absorb moisture and will cause rust. Be sure to empty ash after grill has cooled. Uncoated steel and cast-iron WILL RUST WHEN NOT PROPERLY CARED FOR.
- Do not use self-starting charcoal as it will give unnatural flavor.
- After each use, coat vegetable oil on the interior grates and bare metal while warm to reduce rust.
- On the EXTERIOR, remove rust with wire brush and touch up with a high heat paint, available at most hardware/auto stores.
- You may place a metal can on bottom shelf under the hole in the grill to catch drippings.
- Heat gauge may retain moisture, which will steam out during cooking. Gauge can be removed and calibrated in oven.
- You may fill unwanted holes with Nuts & Bolts (Not Provided).

**NOTE: Smoke may escape from areas other than the smokestack. This will not affect cooking.**

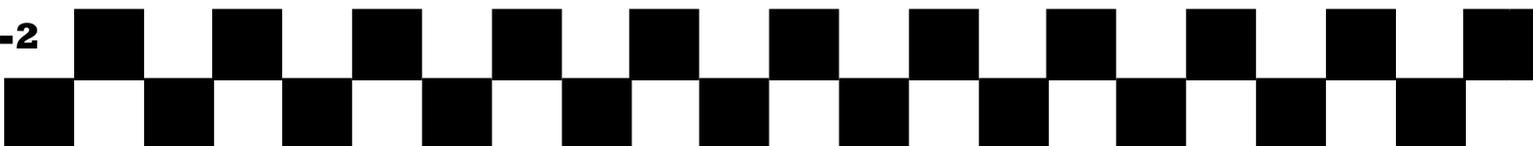

## **Finishing Up**

When you are finished grilling, close both dampers and the hood allowing the fire to suffocate. Wait until coals and ash have completely cooled before attempting to clean up or remove. Be patient. This may take an hour or more.

## **Emptying the Ashes & Ash Pan**

**\*\* ONLY EMPTY ASHES ONCE GRILL IS NOT IN USE AND COOL TO THE TOUCH \*\***

**\*\* DO NOT EMPY ASHES DURING GRILL USE OR WHEN GRILL IS HOT \*\***

Wait until after the fire is completely extinguished and the grill is cool to the touch before emptying the ashes to ensure they are not still hot and a burn hazard.

1. Remove grates from grill with grate lifter.
2. Remove ash pan from grill.
3. Give the ash pan a few firm taps to loosen any ash that may be stuck.
4. Dump the ashes in a metal container and cover with water to ensure there are no lit coals then you can dispose of the ashes.

**IMPORTANT: Charcoal is porous and holds moisture. DO NOT leave charcoal in your grill while you are not using it. Charcoal and ashes left inside the ash pan may reduce the life of your grill.**

# GRILLING RECIPES

## Know Your Cuts of Meat

### BEEF CUTS

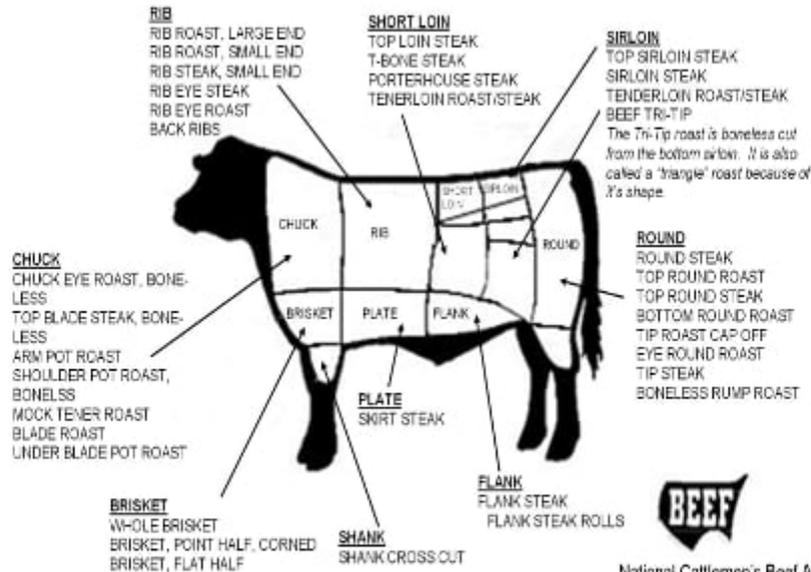

National Cattlemen's Beef Association  
444 North Michigan Avenue  
Chicago, Illinois 60611  
(312) 467-5520

### PORK CUTS

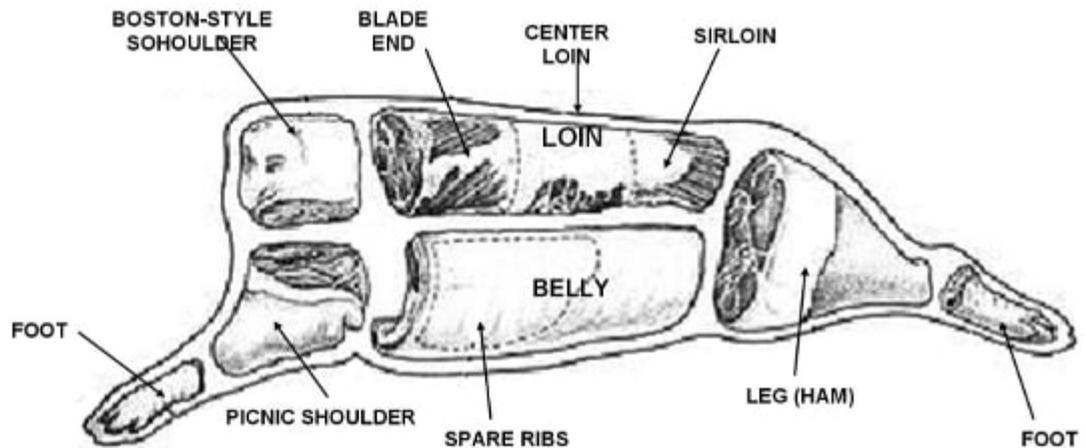



# GRILLING RECIPES

## **Direct Heat**

Direct Heat is a high heat method used to cook foods that take less than 25 minutes to cook. Typically, this means foods that are relatively small or thin, such as steaks, chops, boneless chicken breasts, fish fillets, hamburgers, etc.

- Cooking with a MEAT THERMOMETER ensures food is fully cooked. Insert thermometer into the thickest part of the meat, not touching bone, and allow 1 to 1 1/2 minutes to register temperature.
- Internal temperatures for BIRDS should be 170°F to 180°F or when leg moves easily in joint.
- Internal temperature for meat should be 140°F for rare, 160°F medium, and 170°F for well done.

### **STEAK (& ALL MEATS):**

- To grill meats, set the grill to high heat and sear for one minute on each side with the lid open to seal in flavor and juices. Then lower the heat to medium, close the lid, and cook to desired temperature.

**Tip:** Place grilled meat back in the marinade for several minutes before serving – it will become tastier and juicier.

**CAUTION:** Boil extra marinade first to kill bacteria remaining from the raw meat.

### **MARINATED FLANK STEAK:**

- Mix marinade ingredients in nonmetal dish.
- Let steak stand in marinade for no less than 4 hours in refrigerator.
- Sear each side on high heat for 5 minutes; center should remain rare.
- Cut steak diagonally across the grain into thin slices before serving.

### **Meat Marinade**

1/2 cup Olive Oil  
1/3 cup Soy Sauce  
1/4 cup Red Wine Vinegar  
2 tbsp. Lemon Juice  
1 tsp. Dry Mustard  
1 minced Garlic Clove  
1 small Onion, minced  
1/4 tsp. Pepper

### **QUAIL OR DOVES:**

- Cover birds in Italian dressing (Good Seasons or Kraft Zesty) and marinate overnight.
- Pour remaining dressing and cover with preferred hot sauce. Marinate for 6 hours.
- Wrap birds in thick bacon, and secure with a toothpick.
- Place on grill. Keep turning until bacon is charred.
- Grill for 20 minutes. Sear on high with lid open for 1 minute on each side before lowering heat and closing lid.

### **KABOBS:**

- Alternating on skewers any combination of meat, onions, tomatoes, green peppers, mushrooms, zucchini, circular slice of corn-on-the-cob, or pineapple. Meat could consist of chunks of shrimp, scallops, lobster, chicken, sausage, pork, beef, etc.
- Marinate the meat in refrigerator for several hours.
- Grill each side approximately 7 minutes turning occasionally while basting with marinade. Leave a small amount of room between pieces in order to cook faster.
- Grill with lid open. See marinade recipe on last page.

### **Kabob Marinade:**

1 cup Soy Sauce  
½ cup Brown Sugar  
½ cup Red Wine Vinegar  
½ cup Pineapple Juice  
2 tsp. Salt  
½ tsp. Garlic Powder

- Mix all ingredients in a saucepan and bring to boil.
- Allow marinade to cool before marinating your meat in it.
- Marinate beef in mixture a minimum of 4 hours.

### **HOT DOGS:**

- Grill with lid open for approximately 6 minutes.
- Turn every few minutes.



## **HAMBURGERS:**

See Meat Marinade on previous pages.

You may also marinate by allowing to stand in marinade for 1 or 2 hours at room temperature before cooking, or let stand in covered dish in refrigerator up to 24 hours.

- Bring to room temperature before cooking.
- Mix in chopped onions, green peppers, salt, sear 3/4 inch patties on each side.
- Cook over medium heat with lid down to avoid flare-ups.
- Cook each side 3 to 7 minutes according to desired temperature.
- Cook ground meat to 150°F internally or until juice runs clear (free of blood) for prevention of E-coli.
- Burgers can be basted with marinade when turning and/or other ingredients can be mixed in with the ground beef such as chili sauce or powder.

## **SHRIMP (Peeled) & CRAYFISH:**

- Place on skewers.
- Coat with melted butter and garlic salt.
- Grill 4 minutes on each side or until pink. Cocktail sauce optional.

## **BAKED POTATOES:**

- Rub with butter and wrap in foil and cook on grill with lid down for 50 minutes.
- Turn after 25 minutes (no need to turn if smoked).
- Squeeze to check for doneness.

## **SWEET CORN IN HUSKS:**

- Trim excess silk from end and soak in cold salted water 1 hour before grilling.
- Grill 25 minutes – turning several times.

# SMOKING RECIPES

## Indirect Heat

### SMOKING TIMES

Food	Weight	Water Pan Smokin'	Temperature on Meat Thermometer
Beef Roasts, Beef Brisket	3 – 4 lbs.	1 – 1½ hours	140° rare
Lamb Roasts, Venison	5 – 7 lbs.	1¾ – 2½ hours	160° medium
Large cuts of Game	7 – 9 lbs.	2½ – 3½ hours	170° well done
Pork Roasts	3 – 4 lbs. 5 – 8 lbs.	1¾ – 2½ hours 2½ – 3 hours	170° 170°
Pork/ Beef Ribs	Full grill	1½ – 2 hours	Meat pulls from bone
Pork Chops	Full grill	¾ – 1¼ hour	Meat pulls from bone
Sausage Links	Full grill	2 – 2¾ hours	170° for fresh sausage
Ham, Fresh	10 lbs.	3 – 4 hours	170°
Ham, Cooked	All sizes	1½ – 2 hours	130°
Chicken (Cut up or split)	1-4 fryers, cut up or split	1 – 1¼ hours	180° / leg moves easily in joint
Chicken (Whole)	1-4 fryers	1¼ – 1½ hour	180° / leg moves easily in joint
Turkey (Unstuffed)	8 – 12 lbs.	1¾ – 2½ hours	180° / leg moves easily in joint
Fish, small whole	Full grill	½ – ¾ hours	Flakes with fork
Fish, filets, steak	Full grill	¼ – ½ hours	Flakes with fork
Duck	3 – 5 lbs.	1 – 1¾ hours	180° / leg moves easily in joint
Small game birds	Full grill	¾ – 1 hour	180° / leg moves easily in joint

Pan not included. SMOKE BY COOKING SLOWLY.

1. Place water/drip pan on left side of fire grate.
2. Place hot coals on right side (damper end) of fire grate.
3. Place meat above water pan.
4. Place fire grate in low position.
5. Close lid & control heat with dampers.

**Tip:** Check the water level when cooking more than 4 hours or when you can't hear the water simmering. Add water when necessary.

### SMOKED TURKEY:

- Empty cavity rinse and pat dry with paper towel.
- Tuck wing tips under the back and tie legs together.
- Place in center of cooking grate directly above foil drip pan of water.
- Smoke for 12 minutes per pound. Allow several extra minutes per pound if stuffed to allow for expansion.
- Use a meat thermometer for best results (190°F internal).



## **SMOKED BAKED HAM:**

You can smoke fully cooked canned ham or smoked and cured whole ham or shank or butt portion.

### **Glaze**

1 cup of Light Brown Sugar, firmly packed  
1/2 cup Orange Juice  
1/2 cup Honey

- Combine sugar, juice and honey. Let glaze sit for at least 4 hours.
- Remove rind and score fat diagonally to give a diamond effect.
- Insert a whole clove into the center of every diamond.
- Place ham with fat side up in center of cooking grate. Close lid.
- About 9 minutes per pound is suggested for fully cooked hams. Smoked or cured ham, which is not fully cooked, should be cooked to an internal temperature of 160°F.
- Baste with ham glaze 3 or 4 times during last 30 minutes of cooking time.
- Garnish with pineapple rings about 15 minutes before end of cooking time.

## **SMOKED STUFFED HOT DOGS:**

- Slit hot dogs lengthwise, within 1/4 inch of each end.
- Stuff hot dogs with cheese and relish and wrap in bacon.
- Place on cooking grate over drip pan and smoke 15-20 minutes or until bacon is crisp.

## **SMOKED CHICKEN PARTS AND HALVES:**

- Rinse pieces in cold water and pat dry with paper towels.
- Brush each piece with Olive Oil and season to taste with salt and pepper.
- Brown pieces directly above coals with lid open and grill on high or medium heat for several minutes.
- Then place pieces on cooking grate in indirect cooking area.
- With the grill on low heat, cook with lid down for 55 to 60 minutes or until done. Do not use Olive Oil or salt and pepper if using marinade.

## **SMOKED VENISON WITH BACON:**

### **Venison Marinade:**

1 cup Balsamic or Red Wine Vinegar  
1 cup Olive Oil  
2 oz. Worcestershire  
1/2 oz. Tabasco  
2 tbsp. Seasoning Salt  
1-2 chopped Jalapeños  
3 oz. Soy Sauce

### **Bacon Marinade (for Smoked Venison with Bacon Recipe)**

2 oz. Red Wine Vinegar  
2 oz. Worcestershire  
4 dashes Tabasco

- Place leg of venison in a container and marinate for 2-4 days, turning daily. Leave bacon to marinate overnight.
- Remove leg from refrigerator at least an hour before cooking.
- Season generously with seasoned salt and coarse ground black pepper.
- Wrap 1 lb. bacon over the top of the leg, and smoke 20-25 minutes per pound, or until tender. Do not overcook.

### **SMOKED SHRIMP & CRAYFISH:**

- Mix in a foil pan 1/2 cup butter, two cloves of crushed garlic, Tabasco, sliced green pepper, 1 tablespoon each of minced onions, salt and juices from one lemon.
- Add shrimp and/or crayfish and smoke 45 minutes.

### **SMOKED VEGETABLES:**

- Turnips, potatoes, carrots, okra, mushrooms, peeled onions, zucchini, squash, etc.
- Put in pan and cover with water and cook for several hours while cooking the meat. Or place vegetables on grill and smoke for 50 minutes, either wrapped in foil or not.

### **SMOKED FISH:**

- Marinate in brine (1/4 cup dissolved in 1 qt of water) or marinate fish in 1 cup white wine and 1 cup Soy Sauce mixed with 1 cup Lemon Juice.
- Marinate overnight in covered dish in refrigerator.
- Let air on rack 20 minutes before placing on Pam-sprayed grill.
- Smoke 25 minutes.

### **SMOKED SPARE/BACK RIBS:**

- Peel off tough layer of skin on back side.
- Rub all surfaces with seasoning.
- Place ribs in the indirect cooking area and smoke approximately 1 1/2 hours or until meat pulls away from bone.
- Baste with barbecue sauce during last 30 minutes.



## **CHICKEN MARINADE:**

### **Combine**

1/2 cup Soy Sauce  
1/4 cup Olive Oil  
1/4 cup Red Wine Vinegar  
1 tsp. Oregano  
1/2 tsp. Sweet Basil  
1/2 tsp. Garlic Powder with Parsley  
1/4 tsp. Pepper

- Pour over chicken pieces in non-metal dish
- Cover and refrigerate overnight, turning occasionally. Use marinade to baste chicken while cooking.

## **MEAT MARINADE:** (For steaks, chops, and burgers)

### **Combine**

1/4 cup Soy Sauce  
2 coarsely chopped Large Onions  
2 Garlic Cloves (halved)

- Combine ingredients in an electric blender, cover, and process at high speed 1 minute or until mixture is very smooth.
- Stir in 1/4 cup bottle gravy coloring (Kitchen Bouquet and Gravy Master) and 2 teaspoons Beau Monde seasoning (or substitute 1 teaspoon MSG and 1 teaspoon seasoned salt).
- Allow meat to stand in marinade at room temperature for 2 hours or refrigerate up to 24 hours in a covered dish.
- Bring meat to room temperature before cooking.

## **SHISH KABOB MARINADE:**

### **Combine**

1 cup Soy Sauce  
1/2 cup Brown Sugar  
1/2 cup White Vinegar  
1/2 cup Pineapple Juice  
2 tsps. Salt  
1/2 tsp. Garlic Powder

- Mix ingredients and bring to a boil.
- Marinate beef in mixture a minimum of 4 hours.

# ACCESSORIES



## Custom Fit Cover

Weather Resistant  
Protects Grill Finish  
Cover Accommodates  
Side Shelf or Side Fire Box



## Quick Release Chimney Starter

E-Z starter with patented  
trigger release  
ABS handle with heat shield  
Zinc coated galvanized steel  
Makes starting charcoal grill  
fast and easy



## Folding Probe Thermometer

Stainless steel  
fast-read probe accurately  
measures temperature  
Easily switch from °F to °C  
Auto ON/OFF feature for  
extended battery life



## Apron

Machine Washable  
Two Front Pockets  
Adjustable Straps



## Char-Griller® Trucker Hat

Cotton-poly blended front  
Nylon mesh back  
Adjustable snapback closure  
One Size Fits Most



## Original All-Purpose BBQ Rub

Pairs well with all types of  
meat and fish

**For pricing or to order accessories visit:**

**[www.CharGriller.com](http://www.CharGriller.com)**

**OR**

**CALL: 912-638-4724**



**P.O. Box 30864  
Sea Island, GA 31561  
912-638-4724  
[www.CharGriller.com](http://www.CharGriller.com)  
[Service@CharGriller.com](mailto:Service@CharGriller.com)**

